

Instructions for glueing in the ball guiding bush E 5140

1. How to prepare for glueing

- » Prior to the assembly, clean both guiding bush and bore hole so they are free of oil and grease residues.
- » Use high-performance cleaner VCM 20 by Meusburger to clean both guiding bush and bore hole.

2. How to apply the glue

- » Apply glue Loctite 648 to the outer surface of the guiding bush

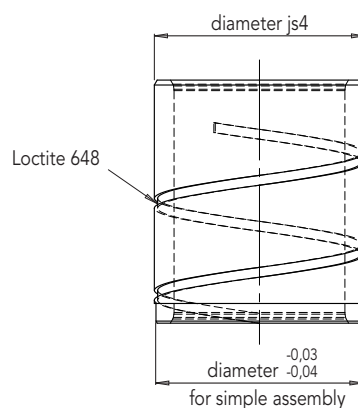

3. How to fit the guiding bush inside the bore hole of the plate

- » Centre the bush with the aid of the chamfer (outer diameter: -0,03/-0,04) inside the bore hole.
- » Insert the guiding bush into the bore hole with a rotating movement.
- » Owing to the glue grooves, an optimal wetting of the bonding surface with glue is ensured.
- » Close the tool and allow the glue to harden for 12 hours.

