

Assembly Table

air-cushioned

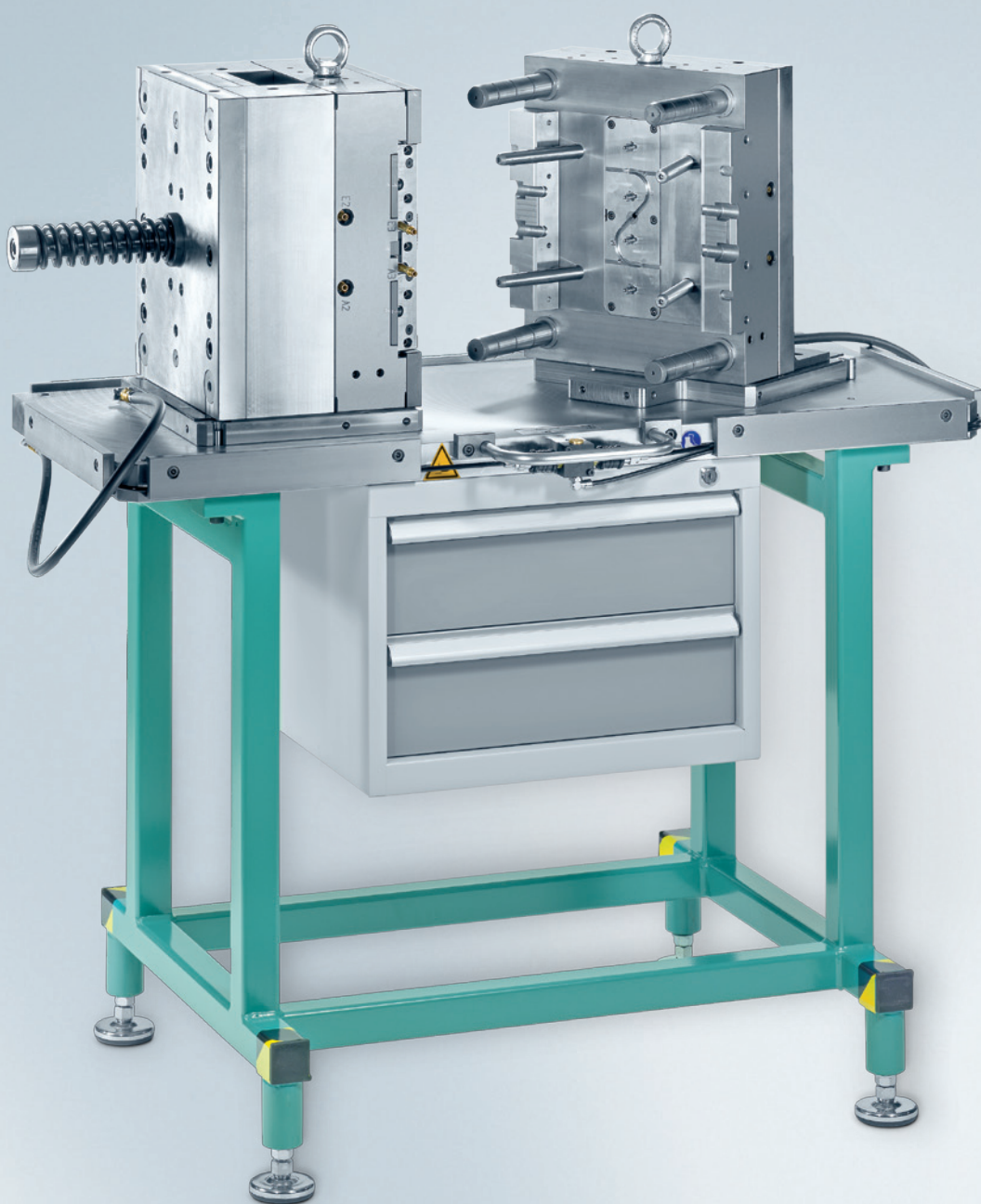

neusburger.com

EUR 2012

An innovative in-house development

The air-cushioned assembly table substantially facilitates operations for repair and assembly work on injection moulding, die casting and punching tools. By way of many air nozzles, an air cushion is created on the underside of the moveable pallets which enables light and easy movement of the mould halves.

How you benefit:

More efficient operating and increased productivity

- » separate control allowing unrestricted movement of both mould halves, without any effort
- » both mould halves are freely accessible without having to reposition or turn them around
- » sturdy table withstanding strong impacts
- » compact and simple design
- » load capacity up to 3.000 kg

Time and expenses saving

- » reduced fitting times
- » easy handling

More safety and protection

- » for the personnel
- » for the valuable tools
- » narrow mould halves can be fixed with a mounting bracket

CE Certification Machinery Directive 2006/42 EG

Feel free to request a quote by fax 00 43 (0) 55 74 / 67 06 -11 or e-mail sales@meusburger.com

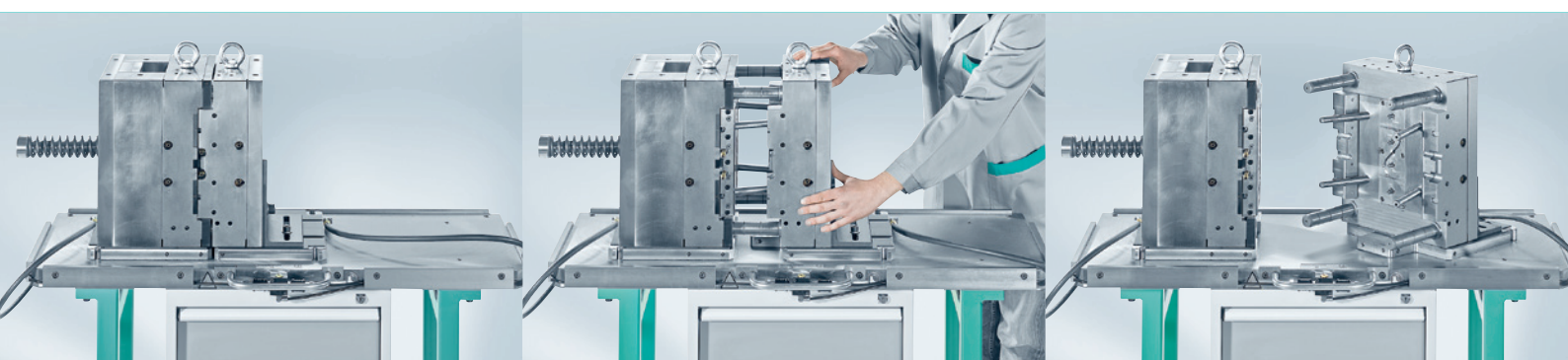

H 4062 Air-cushioned assembly table with stand and tool cabinet

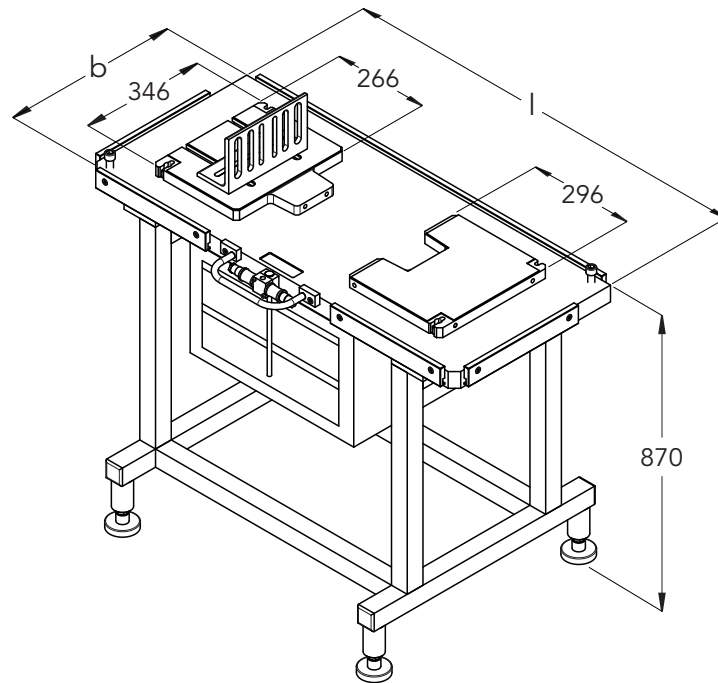

Mat.: 1.1730	Load capacity: 3.000 kg		p = 6 bar
b	l	No.	EUR/1
496	1156	H 4062/496/1156	4.700,00

Complete set including:	1 copper hammer	2 levers
	4 eye bolts E 1270/16	1 high efficiency multi oil VMM 4/1/400

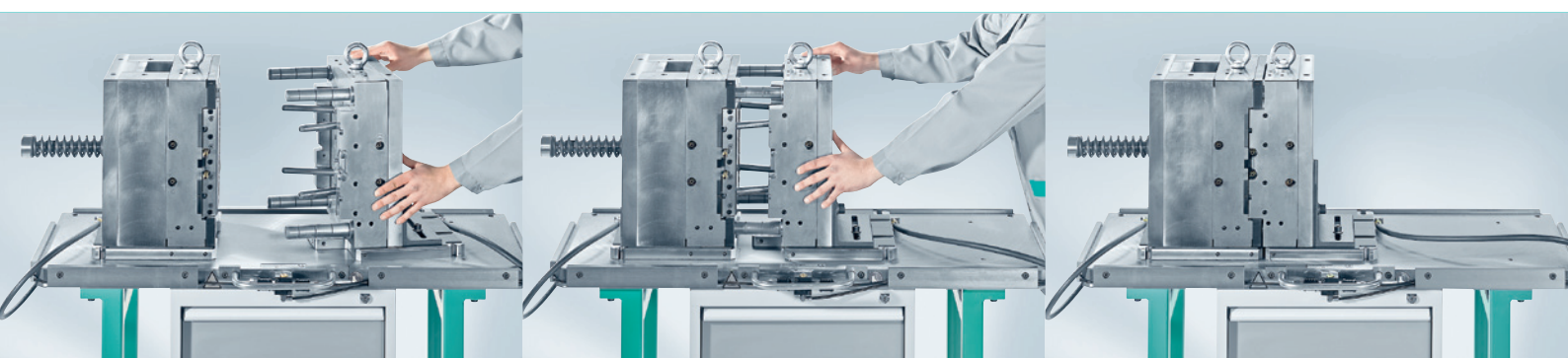

© 2012/ Meusbürger Georg GmbH & Co KG. All rights reserved. No extract of these documents may be duplicated or transmitted for whatever purposes without the explicit and written authorization of Meusbürger Georg GmbH & Co KG. Printing or other errors excepted. Technical details subject to changes.

meusbürger.com

Meusbürger Georg GmbH & Co KG | Standard moulds | Kesselstr. 42 | A-6960 Wolfurt
T 00 43 (0) 55 74 / 67 06-0 | F -11 | sales@meusburger.com | www.meusburger.com