

Wechselformen

Change Moulds

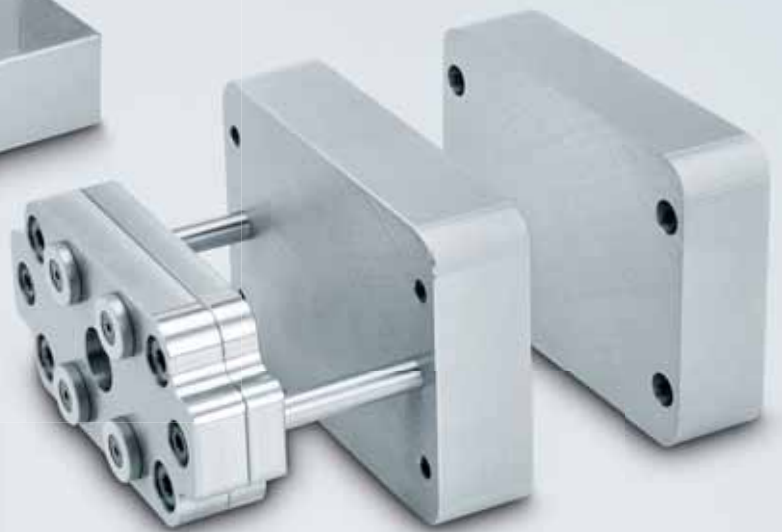

meusburger.com

EUR 2011

Wechselformen – Einfach und präzise

Change Moulds – Simple and precise

Meusbürger Wechselformen sind die ideale Lösung zur schnellen und kostengünstigen Realisierung von Kleinserien und Prototypen. Durch das neu entwickelte Wechselsystem mit Positionierkeilen können die Einsätze sehr einfach und schnell, aber dennoch präzise und wiederholgenau gewechselt werden.

Nutzen Sie die Wechselformen von Meusbürger und profitieren Sie von zahlreichen Vorteilen

- » Realisieren Sie Ihre Prototypen in kürzester Zeit durch einbaufertige Formeinsätze
- » Profitieren Sie von der stabilen und langlebigen Bauweise eines geschlossenen Formrahmens aus korrosionsbeständigem Stahl
- » Sparen Sie Kosten durch stark verkürzte Durchlaufzeiten und reduziertem Materialaufwand
- » Wechseln Sie die Formeinsätze mit Auswerferpaket auf der Spritzgießmaschine
- » Minimieren Sie Ihren Maschinenstillstand durch kurze Wechselzeiten mit Hilfe unserer neu entwickelten Auswerferpaketkupplung

Meusbürger Change Moulds are the ideal solution for the quick and cost saving making of prototypes or small series. With the newly developed change system with positioning wedges, the inserts can be changed very easily and quickly with a high repeat accuracy.

Benefit from the Meusbürger Change Moulds and their numerous advantages

- » Make your prototypes in no time at all with ready-to-use mould inserts
- » Enjoy the benefit of a strong and durable construction of a closed mould frame made of corrosion resistant steel
- » Save on costs through strongly shortened processing times and less material required
- » Change the mould inserts with the ejector set, the mould remaining on the injection moulding machine
- » Minimize your machine standstill times through quick changes made possible with our newly developed ejector set coupling

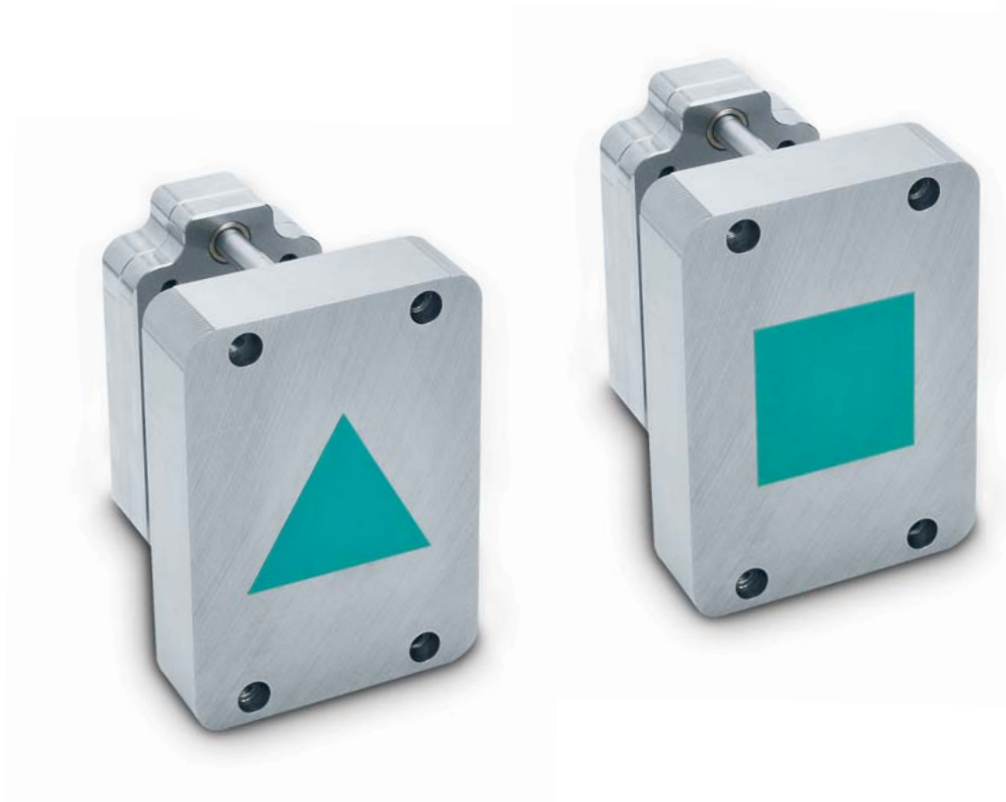

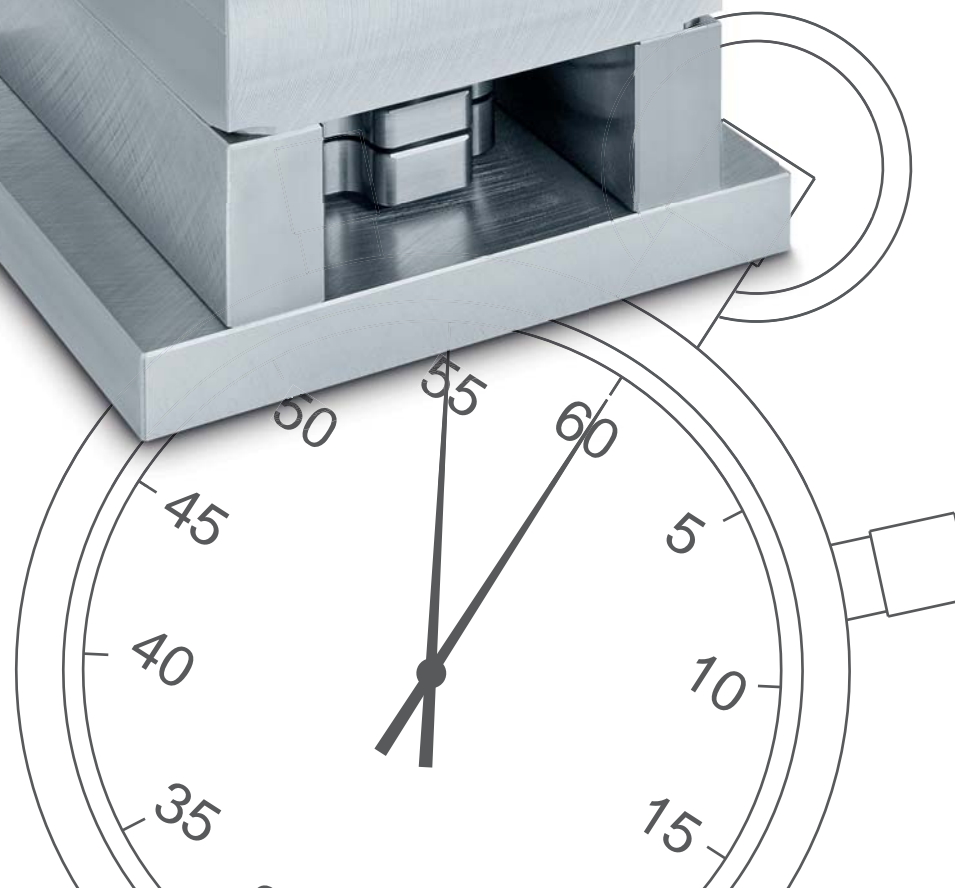
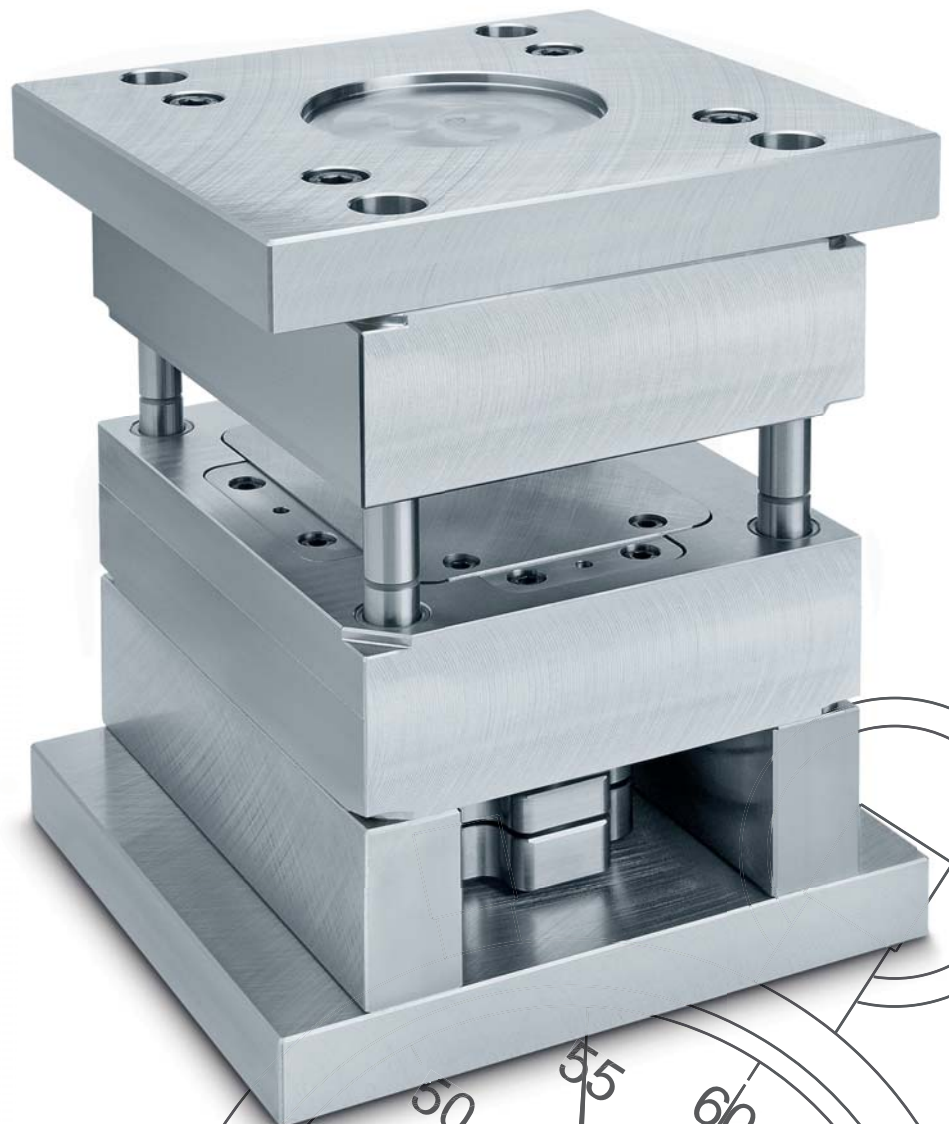

Einsatzwechsel

Insert change

Mit einfachen Handgriffen können die Wechseleinsätze komfortabel und vor allem wiederholgenau gewechselt werden.

With no more than a few manual operations you can easily change the inserts and still maintain a high level of repeat accuracy.

Auswerferpaket von der Maschine mit Kupplung ① oder Schraubverbindung ② entkoppeln. Die Befestigungsschrauben ③ der Einsätze entfernen.

Uncouple the ejector set from the moulding machine with the coupler ① or with the screw connection ②. Remove the mould insert fastening screws ③.

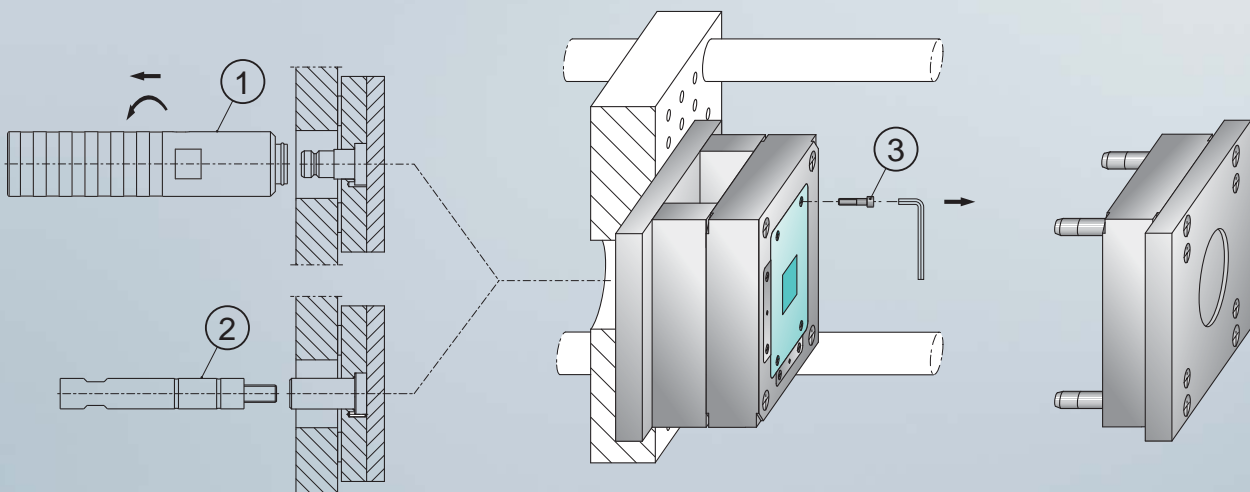

Schrauben ④ lösen. Positionierkeile mittels Gewindestift ⑤ abdrücken.

Loosen the fastening screws ④. Screw in the set screws ⑤ to disengage the wedges.

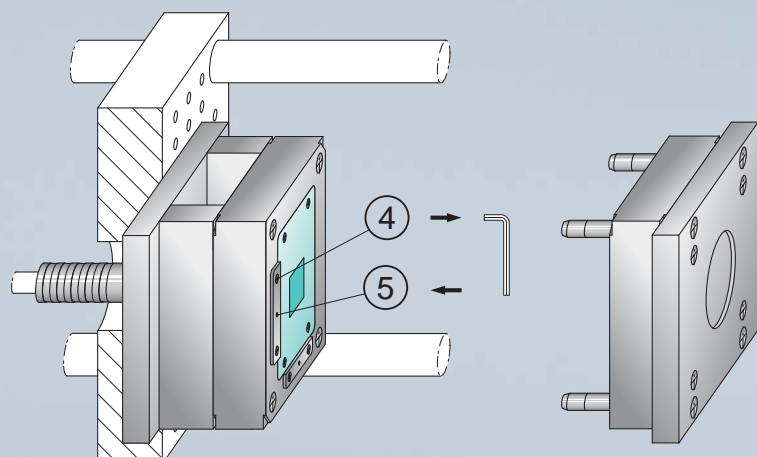

Wechseleinsatz samt Auswerferpaket mit Hilfe von Schrauben herausziehen.
Pull out the change insert with the attached ejector set using screws.

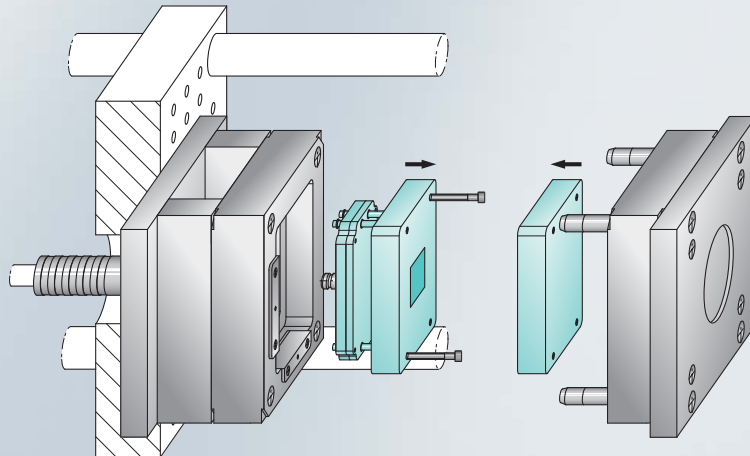

Nächsten Einsatz einsetzen und Befestigungsschrauben ③ leicht anziehen. Gewindesttift ⑤ in Ausgangstellung zurückdrehen. Positionierkeile mit Schrauben ④ festziehen.
Introduce the new insert and screw in the fastening screws ③ without tightening. Turn the set screws ⑤ to the initial position. Fasten the wedges with screws ④.

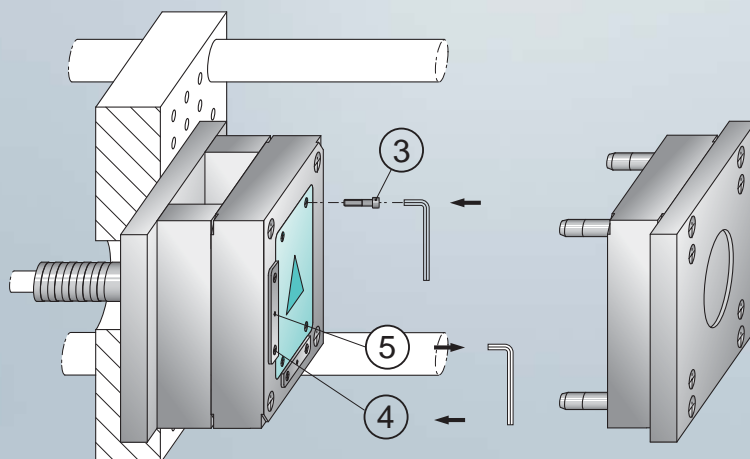

Einsätze mit Schrauben ③ festziehen. Auswerferpaket an die Maschine koppeln.
Fasten the insert with screws ③. Couple the ejector set to the machine.

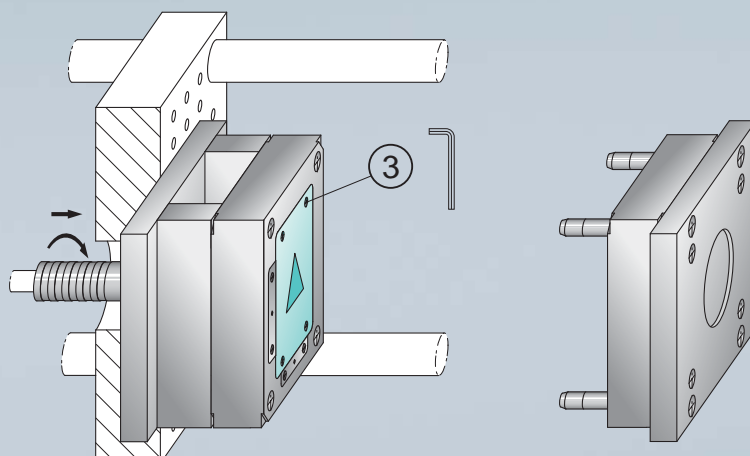

Materialqualitäten

Werkst.-Nr.	Bezeichnung	Richtanalyse	Festigkeit	Charakter	Verwendung
1.1730	DIN: C 45 U AFNOR: XC 48 AISI: 1045	C - 0.45 Si - 0.30 Mn - 0.70	≈ 640 N/mm ²	Werkzeugstahl unlegiert, flammhärtbar	ungehärtete Bauteile für den Werkzeug- und Vorrichtungsbau bzw. Platten und Rahmen für Formaufbauten und Säulengestelle
1.2083	DIN: X 42 Cr 13 AFNOR: Z 40 C 14 AISI: 420	C - 0.42 Si - 0.40 Mn - 0.30 Cr - 13.00	≈ 780 N/mm ²	Durchhärterstahl korrosionsarm	Formplatten und Einsätze für die Kunststoffverarbeitung, vorwiegend bei Verarbeitung chemisch aggressiver Kunststoffe
1.2085	DIN: X 33 CrS 16 AFNOR: Z 35 CD 17.S AISI: ≈ 422+S	C - 0.33 Si - 0.30 Mn - 0.80 Cr - 16.00 Mo - 1.20 S - 0.06 Ni - 0.30	≈ 1080 N/mm ²	Werkzeugstahl vorvergütet, korrosionsbeständig, gut zerspanbar	Platten für korrosionsbeständige Formaufbauten und Säulengestelle, Formplatten für chemisch aggressive Kunststoffe
1.2162	DIN: 21 MnCr 5 AFNOR: 20 MC 5 AISI: 5120	C - 0.21 Si - 0.25 Mn - 1.25 Cr - 1.20	≈ 660 N/mm ²	Einsatzstahl legiert	Formplatten, Einsätze und Maschinenbauteile
1.2210	DIN: 115 CrV3 AFNOR: 100 C3 UNI: 107 CrV3 KU AISI: L2	C - 1.28 Si - 0.25 Mn - 0.30 Cr - 0.70 Ni - 0.10 Ti - 0.20	≈ 740 N/mm ²	Kaltarbeitsstahl legiert, verschleißfest	Kernstifte, Stempel, kleine Drehteile
1.2311	DIN: 40 CrMnMo 7 AFNOR: 40 CMD 8 UNI: 35 CrMo 8 KU AISI: P20	C - 0.40 Si - 0.40 Mn - 1.50 Cr - 1.90 Mo - 0.20	≈ 1080 N/mm ²	Werkzeugstahl legiert und vergütet, flammhärtbar, speziell geeignet zum Nitrieren, polierfähig	Formplatten, Einsätze, hochfeste Maschinenbauteile
1.2312	DIN: 40 CrMnMoS 86 AFNOR: 40 CMD 8.S AISI: P20+S	C - 0.40 Si - 0.40 Mn - 1.50 Cr - 1.90 Mo - 0.20 S - 0.06	≈ 1080 N/mm ²	Werkzeugstahl legiert und vergütet, gut zerspanbar, flammhärtbar	Platten für Formaufbauten und Säulengestelle mit erhöhter Anforderung an Festigkeit
1.2343	DIN: X 38 CrMoV 51 AFNOR: Z 38 CDV 5 UNI: X 37 CrMoV 51 KU AISI: H11	C - 0.38 Si - 1.00 Mn - 0.40 Cr - 5.30 Mo - 1.20 V - 0.40	≈ 780 N/mm ²	Warmarbeitsstahl legiert	Formplatten und Formeinsätze für Druckgussformen (Al, Mg, Zn etc.) und Kunststoffwerkzeuge
1.2343 ESR (ESR)	DIN: X 38 CrMoV 51 AFNOR: Z 38 CDV 5 UNI: X 37 CrMoV 51 KU AISI: H11 ESR	C - 0.38 Si - 1.00 Mn - 0.40 Cr - 5.30 Mo - 1.20 V - 0.40	≈ 780 N/mm ²	Warmarbeitsstahl legiert, hochglanzpolierfähig, elektrisch umgeschmolzen	Formplatten und Formeinsätze für Druckgussformen (Al, Mg, Zn etc.) und Kunststoffwerkzeuge
1.2379	DIN: X 155 CrVMo 121 AFNOR: Z 160 CDV 12 UNI: X 155 CrVMo 12 1 KU AISI: ≈ D2	C - 1.53 Si - 0.30 Mn - 0.35 Cr - 12.00 Mo - 0.80 V - 0.80	≈ 850 N/mm ²	Durchhärterstahl verschleißfester Kaltarbeitsstahl	Formplatten und Einsätze sowie Druck- und Schneidplatten mit erhöhter Verschleißfestigkeit

Werkst.-Nr.	Bezeichnung	Richtanalyse	Festigkeit	Charakter	Verwendung
1.2767	DIN: X 45 NiCrMo 4 AFNOR: 45 NCD 16 UNI: 40 NiCrMoV 16 KU AISI: 6F7	C - 0.45 Si - 0.25 Mn - 0.40 Cr - 1.35 Mo - 0.25 Ni - 4.00	≈ 830 N/mm ²	Durhhärterstahl speziell legiert, polierfähig, hohe Druck- und Biegefestigkeit	anspruchsvolle Formplatten und Einsätze; Schneid- und Biegeeinsätze für hohe Druckbelastungen
1.2842	DIN: 90 MnCrV 8 AFNOR: 90 MV 8 UNI: 90 MnVCr 8 KU AISI: ≈ O2	C - 0.90 Si - 0.20 Mn - 2.00 Cr - 0.40 V - 0.10	≈ 760 N/mm ²	Durhhärterstahl maßbeständig bei hoher Härtheit, verschleißfester Kaltarbeits- stahl, sehr gut bearbeitbar	Formplatten, Einsätze für abrasive Belastung; Druck-, Schneid- und Führungsplatten; Druck- und Führungsleisten
1.7131	DIN: 16 MnCr 5 AFNOR: 16 MC 5 AISI: 5115	C - 0.16 Si - 0.25 Mn - 1.15 Cr - 0.95	≈ 660 N/mm ²	Einsatzstahl legiert	Führungsteile, Kerneinsätze und Maschinenbauteile
3.4365 (AW-7075)	DIN: AlZnMgCu 1.5 EN: ISO 7075 AFNOR: A-Z5GU UNI: 9007/2	Si - 0.40 Fe - 0.50 Cu - 1.60 Mn - 0.30 Mg - 2.40 Cr - 0.23 Zn - 5.60 Ti - 0.20	≤ 540 N/mm ² (dickenabhängig)	Aluminium-Zink-Legierung hochfest, ausgehärtet	Platten für Formaufbauten und Säulengestelle mit erhöhter Anforderung an Festigkeit

Diese Angaben sind Empfehlungen, die jedermann frei zur Anwendung stehen. Im konkreten Fall muss jeder selbst für die richtige Anwendung Sorge tragen. Bei Unklarheiten sollte eine Rücksprache mit dem jeweiligen Spezialisten (z.B.: Stahlhersteller, Härterei) erfolgen. Eine Haftung von "Georg Meusbürger GmbH & Co KG" ist ausgeschlossen.

Material grades

material no	designation	indicatory analysis	strength	character	application
1.1730	DIN: C 45 U AFNOR: XC 48 AISI: 1045	C - 0.45 Si - 0.30 Mn - 0.70	≈ 640 N/mm ²	tool steel plain steel	unhardened parts for the mould and jig construction or plates and frames for tools and dies
1.2083	DIN: X 42 Cr 13 AFNOR: Z 40 C 14 AISI: 420	C - 0.42 Si - 0.40 Mn - 0.30 Cr - 13.00	≈ 780 N/mm ²	steel for through hardening low corrosion	cavity plates and inserts for the processing of plastics, mainly when chemically aggressive melts are being used
1.2085	DIN: X 33 CrS 16 AFNOR: Z 35 CD 17.S AISI: ≈ 422+S	C - 0.33 Si - 0.30 Mn - 0.80 Cr - 16.00 Mo - 1.20 S - 0.06 Ni - 0.30	≈ 1080 N/mm ²	tool steel pre-toughend, corrosion resistant, with good cutting properties	plates for corrosion resistant mould tools and dies, cavity plates for chemically aggressive plastics
1.2162	DIN: 21 MnCr 5 AFNOR: 20 MC 5 AISI: 5120	C - 0.21 Si - 0.25 Mn - 1.25 Cr - 1.20	≈ 660 N/mm ²	steel for case-hardening alloyed	moulding plates, inserts and machine parts
1.2210	DIN: 115 CrV3 AFNOR: 100 C3 UNI: 107 CrV3 KU AISI: L2	C - 1.18 Si - 0.25 Mn - 0.30 Cr - 0.70 Ni - 0.10 Ti - 0.20	≈ 740 N/mm ²	cold-work steel alloyed, wear-resistant	core pins, punches, small turned parts
1.2311	DIN: 40 CrMnMo 7 AFNOR: 40 CMD 8 UNI: 35 CrMo 8 KU AISI: P20	C - 0.40 Si - 0.40 Mn - 1.50 Cr - 1.90 Mo - 0.20	≈ 1080 N/mm ²	tool steel alloyed and pre-toughend, good suitability for flame-hardening, nitriding and polishing	moulding plates, inserts and high-tensile machine parts
1.2312	DIN: 40 CrMnMoS 86 AFNOR: 40 CMD 8.S AISI: P20+S	C - 0.40 Si - 0.40 Mn - 1.50 Cr - 1.90 Mo - 0.20 S - 0.06	≈ 1080 N/mm ²	tool steel alloyed and pre-toughend, good cutting properties, especially suitable for flame-hardening	plates for mould tools and dies with enhanced requirements on strength
1.2343	DIN: X 38 CrMoV 51 AFNOR: Z 38 CDV 5 UNI: X 37 CrMoV 51 KU AISI: H11	C - 0.38 Si - 1.00 Mn - 0.40 Cr - 5.30 Mo - 1.20 V - 0.40	≈ 780 N/mm ²	hot-work steel alloyed	moulding plates and inserts for die casting (Al, Mg, Zn etc.) and injection mould tools
1.2343 ^{ESU} (ESR)	DIN: X 38 CrMoV 51 AFNOR: Z 38 CDV 5 UNI: X 37 CrMoV 51 KU AISI: H11 ESR	C - 0.38 Si - 1.00 Mn - 0.40 Cr - 5.30 Mo - 1.20 V - 0.40	≈ 780 N/mm ²	hot-work steel alloyed, suitable for mirror polishing, electrically remelted	moulding plates and inserts for die casting (Al, Mg, Zn etc.) and injection mould tools
1.2379	DIN: X 155 CrVMo 121 AFNOR: Z 160 CDV 12 UNI: X 155 CrVMo 12 1 KU AISI: ≈ D2	C - 1.53 Si - 0.30 Mn - 0.35 Cr - 12.00 Mo - 0.80 V - 0.80	≈ 830 N/mm ²	steel for through hardening wear-resistant cold-work steel	cavity plates and inserts as well as pressure or cutting plates with increased wear resistance

material no	designation	indicatory analysis	strength	character	application
1.2767	DIN: X 45 NiCrMo 4 AFNOR: 45 NCD 16 UNI: 40 NiCrMoV 16 KU AISI: 6F7	C - 0.45 Si - 0.25 Mn - 0.40 Cr - 1.35 Mo - 0.25 Ni - 4.00	≈ 830 N/mm ²	steel for through hardening special alloy suitable for polishing, high resistance to pressure and good flexural strength	demanding cavity plates and inserts; cutting and bending inserts for high compressive loads
1.2842	DIN: 90 MnCrV 8 AFNOR: 90 MV 8 UNI: 90 MnVCr 8 KU AISI: ≈ O2	C - 0.90 Si - 0.20 Mn - 2.00 Cr - 0.40 V - 0.10	≈ 775 N/mm ²	steel for through hardening dimensional steadiness, high hardness, wear-resistant, cold-work steel of very good cutting properties	cavity plates and inserts exposed to abrasive stress; pressure, cutting and guiding plates; pressure and guiding rails
1.7131	DIN: 16 MnCr 5 AFNOR: 16 MC 5 AISI: 5115	C - 0.16 Si - 0.25 Mn - 1.15 Cr - 0.95	≈ 660 N/mm ²	steel for case-hardening alloyed	round inserts and machine parts
3.4365 (AW-7075)	DIN: AlZnMgCu 1.5 EN: ISO 7075 AFNOR: A-Z5GU	Si - 0.40 Fe - 0.50 Cu - 1.60 Mn - 0.30 Mg - 2.40 Cr - 0.23 Zn - 5.60 Ti - 0.20	≤ 540 N/mm ² (depending on thickness)	aluminium - zinc alloy high-strength	plates for mould tools and dies with enhanced requirements on strength

These general informations are recommendations that everyone be free to apply. For the individual case, the buyer has to make sure for the right application. In case of doubt, a respective specialist (eg. steel manufacturer, hardening shop) should be consulted.



A liability of "Georg Meusburger GmbH & Co KG" is excluded.

FW – Wechselformen

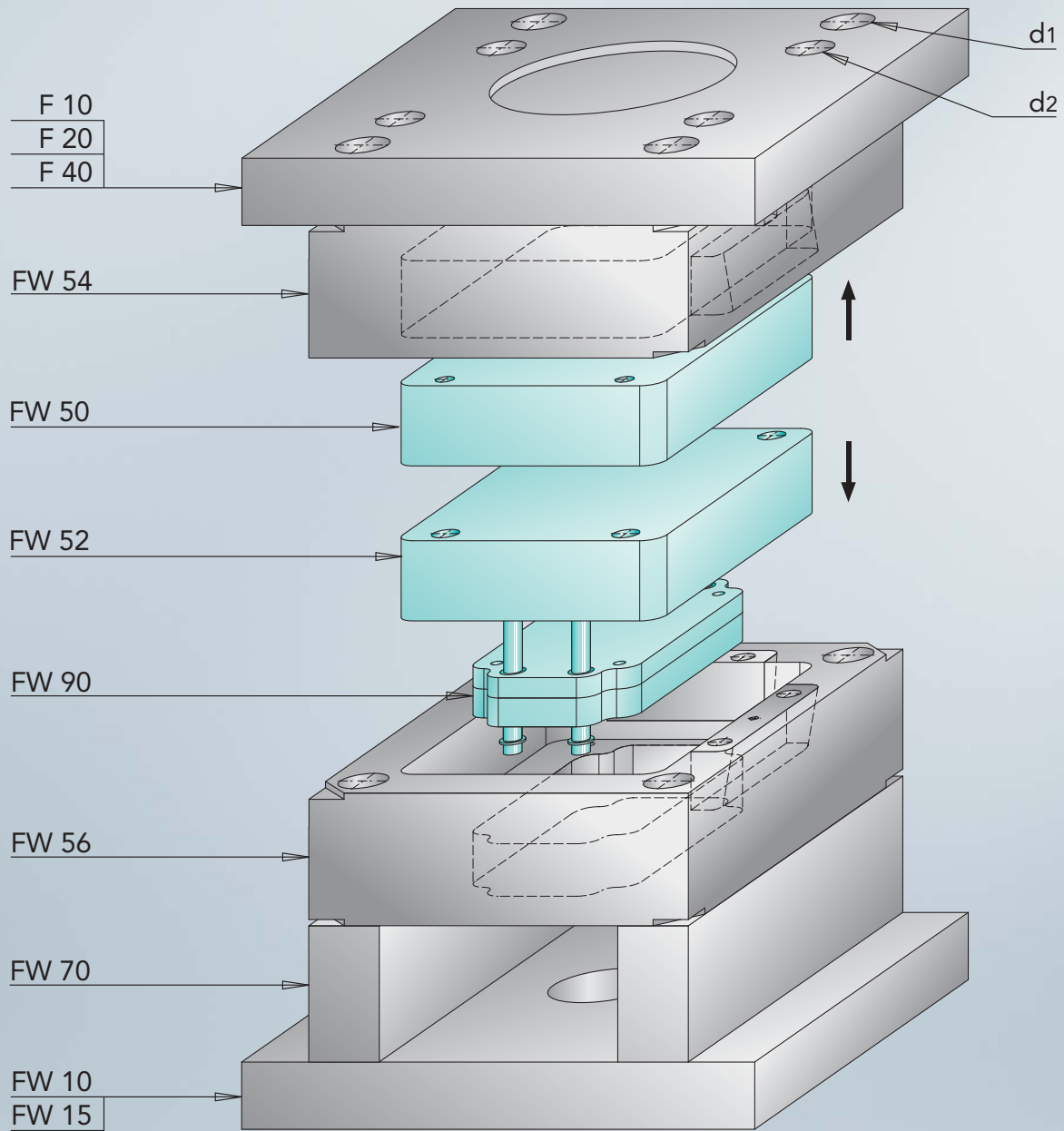
FW – Change Moulds

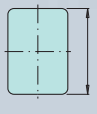

Info Material ⇨ Seite 14
 Info steel grade ⇨ page 16

B	L	d1	d2				Seite page
156	196	20	M10	100	140	25/32/40	290
196	246	26	M10	130	180	32/40/50	292
246	296	30	M12	170	220	40/50/60	294

F 10	Aufspannplatte, Breite überstehend, mit Zentriereindrehung Clamp plate, width salient, with location ring recess
FW 10	Aufspannplatte für Wechselform, Breite überstehend, mit Zentriereindrehung Clamp plate for change mould, width salient, with location ring recess
FW 15	Aufspannplatte für Wechselform, Breite überstehend, ohne Zentriereindrehung Clamp plate for change mould, width salient, without location ring recess
F 20	Aufspannplatte, Länge überstehend, mit Zentriereindrehung Clamp plate, length salient, with location ring recess
F 40	Aufspannplatte, bündig, mit Zentriereindrehung Flush clamp plate with location ring recess
FW 50	Wechseleinsatz, düsenseitig Change insert, fixed half
FW 52	Wechseleinsatz, auswerferseitig Change insert, moving half
FW 54	Wechselformplatte düsenseitig, komplett Change mould fixed half cavity plate, complete
FW 56	Wechselformplatte auswerferseitig, komplett Change mould moving half cavity plate, complete
FW 70	Leiste für Wechselform Riser for change mould
FW 90	Auswerferpaket für Wechselform Ejector set for change mould



CAD download

www.meusburger.com/download



Bestellbeispiel
ordering example

Artikel				Werkstoff
article	B	L	S	steel grade

FW 50 / 156 196 / 32 / 2311

156 196

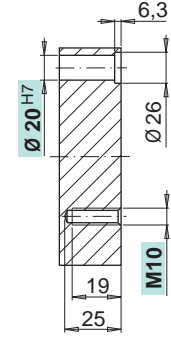
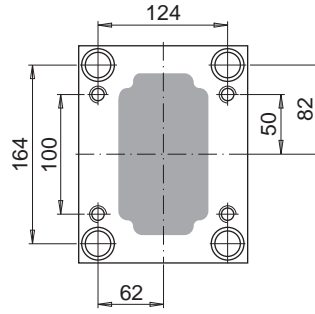
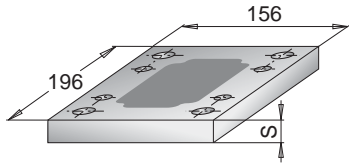

F 10
F 15

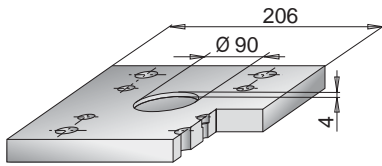
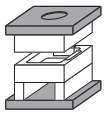

F 10 / 156 196 / S / 1730 2085

22	●	●
27	●	●

F 15 / 156 196 / S / 1730 2085

22	●	●
27	●	●

FW 10
FW 15

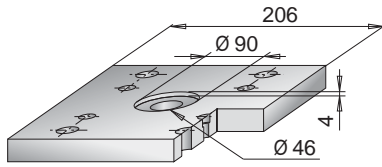
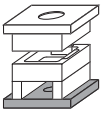

FW 10 / 156 196 / S / 1730 2085

27	●	●
----	---	---

FW 15 / 156 196 / S / 1730 2085

27	●	●
----	---	---

F 20
F 25

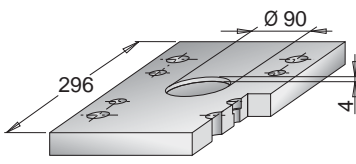
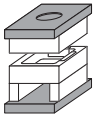

F 20 / 156 196 / S / 1730 2085

22	●	●
27	●	●

F 25 / 156 196 / S / 1730 2085

22	●	●
27	●	●

F 40
F 45

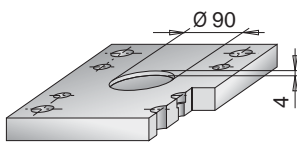
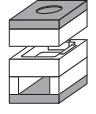

F 40 / 156 196 / S / 1730 2085

17	●	
22	●	●
27	●	

F 45 / 156 196 / S / 1730 2085

17	●	
22	●	●
27	●	

F 60

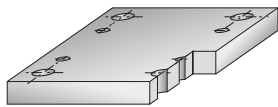
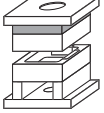

F 60 / 156 196

/ S / 1730 2085 2312

22	●	●	●
27	●	●	●
36	●	●	●
46	●	●	●
56	●		
66	●		

FW 54

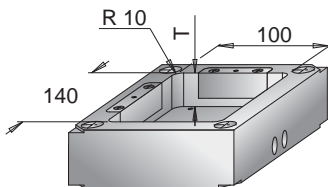
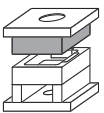

FW 54 / 156 196

/ S / T / 2085 2312

E 1200/ 6 x ..
E 2130/ 6 x 2
E 1302/ 5 x 16
E 2670/ 13/..

46	25	●	●
56	32	●	●
66	40	●	●

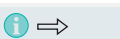

FW 56

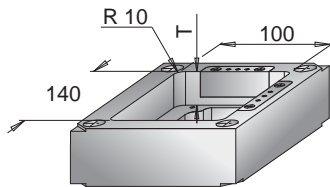
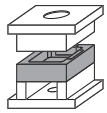

FW 56 / 156 196

E 1200/ 6 x
E 2130/ 6 x 2
E 1302/ 5 x16
E 2670/13/..



/ S / T /	2085	2312
46 25	●	●
56 32	●	●
66 40	●	●

FW 70

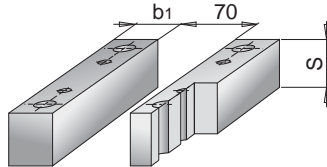
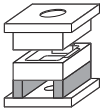

FW 70 / 156 196

T (FW 56)	S
25	46
32	56
40	66

/ b1 / S / 1730	2085
43 46	●
56 66	●

FW 50

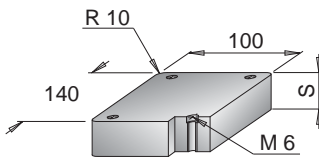

FW 50 / 156 196

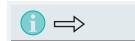

/ S /	2311	3.4365
25	●	●
32	●	●
40	●	●

FW 52

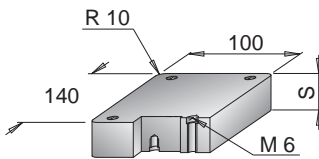

FW 52 / 156 196

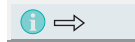

/ S /	2311	3.4365
25	●	●
32	●	●
40	●	●

NF 2660

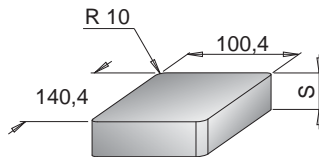

NF 2660 / 100 140



/ S / R /	2083	2311	2343 ^{ESU}	2767
25 10	●	●	●	●
32	●	●	●	●
40	●	●	●	●
50	●	●	●	●
60	●	●	●	●
70	●	●	●	●

FW 90

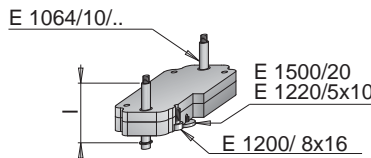
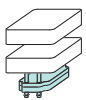

FW 90 / 156 196



/ l / 1730	2085
60	●
73	●
85	●

E 1516

Gewindeinsatz für Auswerferpaket
Threaded insert for ejector set

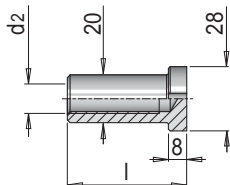

Mat.: 1.7131 ≈ 660 N/mm²

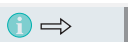

d2	l	Nr. /No.
M12	45	E 1516/12/45
	65	E 1516/12/65

E 1517

Zapfen für Auswerferpaketkupplung
Dowel for ejector set coupling

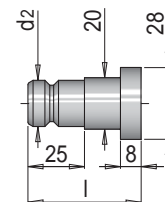

Mat.: 1.2379 ≈ 56 HRC



d2	l	Nr. /No.
18	47	E 1517/18/47

196 246

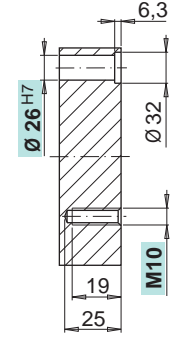
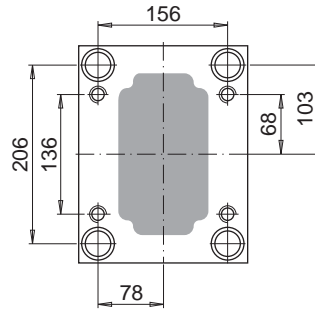
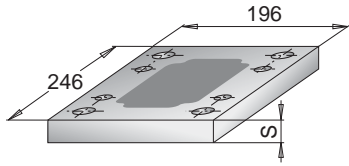

F 10
F 15

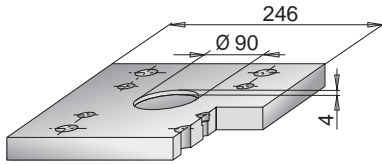
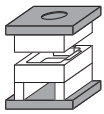

F 10 / 196 246 / S / 1730 2085

S	1730	2085
22	●	●
27	●	●
36	●	

F 15 / 196 246 / S / 1730 2085

S	1730	2085
22	●	●
27	●	●
36	●	

FW 10
FW 15

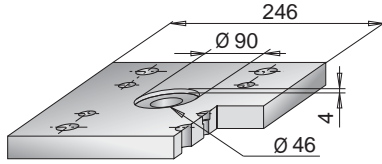
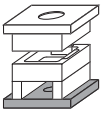

FW 10 / 196 246 / S / 1730 2085

S	1730	2085
27	●	●

FW 15 / 196 246 / S / 1730 2085

S	1730	2085
27	●	●

F 20
F 25

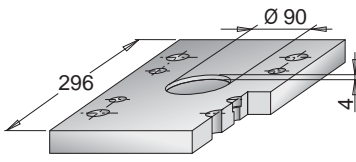
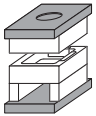

F 20 / 196 246 / S / 1730 2085

S	1730	2085
22	●	●
27	●	●
36	●	

F 25 / 196 246 / S / 1730 2085

S	1730	2085
22	●	●
27	●	●
36	●	

F 40
F 45

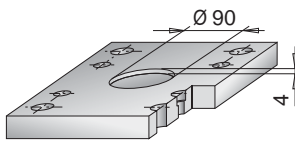
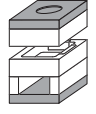

F 40 / 196 246 / S / 1730 2085

S	1730	2085
22	●	●
27	●	●

F 45 / 196 246 / S / 1730 2085

S	1730	2085
22	●	●
27	●	●

F 60

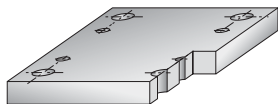
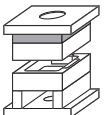

F 60 / 196 246

S	1730	2085	2312
22	●	●	●
27	●	●	●
36	●	●	●
46	●	●	●
56	●		●
66	●		

FW 54

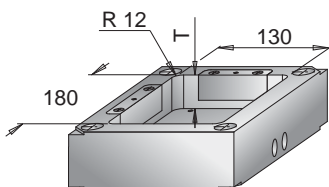
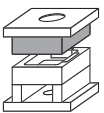

FW 54 / 196 246

E 1200/ 8 x ..
E 2130/ 6 x 2
E 1302/ 5 x 16
E 2670/ 16/..
E 1200/ 6 x ..

S	T	2085	2312
56	32	●	●
66	40	●	●
76	50	●	●



FW 56

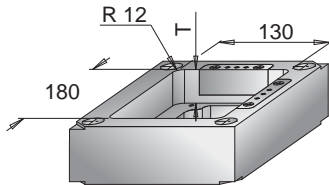
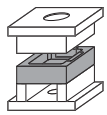

FW 56 / 196 246

- E 1200/ 8 x
- E 2130/ 6 x 2
- E 1302/ 5 x16
- E 2670/16/..
- E 1200/ 6 x



		/ S / T /	2085	2312
56	32		●	●
66	40		●	●
76	50		●	●

FW 70

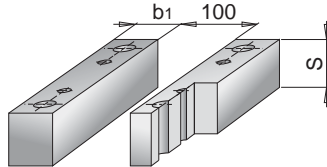
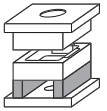

FW 70 / 196 246

T (FW 56)	S
32	56
40	66
50	76

		/ b1 / S / 1730	2085
48	56	●	●
	66	●	●
	76	●	●

FW 50

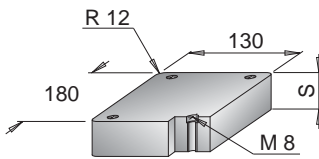

FW 50 / 196 246

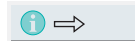

		/ S /	2311	3.4365
	32		●	●
	40		●	●
	50		●	●

FW 52

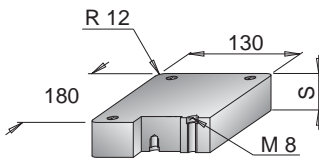

FW 52 / 196 246



		/ S /	2311	3.4365
	32		●	●
	40		●	●
	50		●	●

NF 2660

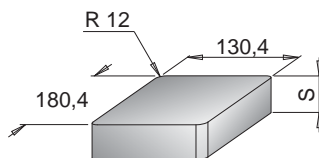

NF 2660 / 130 180



		/ S / R /	2083	2311	2343 ^{ESU}	2767
32	12		●	●	●	●
40			●	●	●	●
50			●	●	●	●
60			●	●	●	●
70			●	●	●	●

FW 90

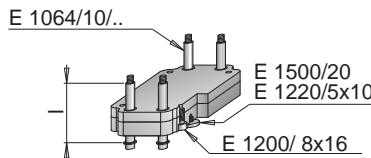
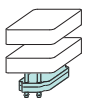

FW 90 / 196 246



		/ I / 1730	2085
	73	●	●
	85	●	●
	95	●	●

E 1516

Gewindeinsatz für Auswerferpaket
Threaded insert for ejector set

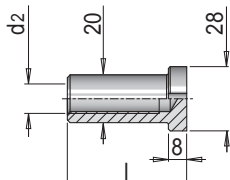

Mat.: 1.7131 ≈ 660 N/mm²



d2	l	Nr. /No.
M12	45	E 1516/12/45
	65	E 1516/12/65

E 1517

Zapfen für Auswerferpaketkupplung
Dowel for ejector set coupling

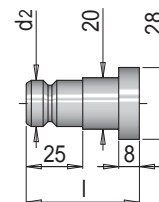

Mat.: 1.2379 ≈ 56 HRC



d2	l	Nr. /No.
18	47	E 1517/18/47

246 296

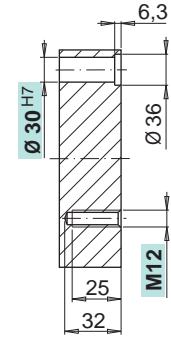
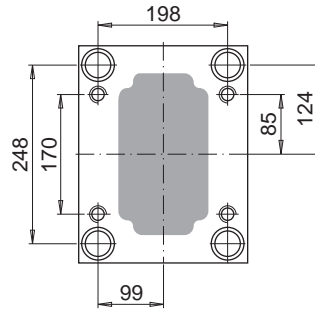
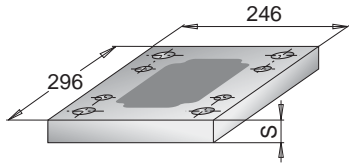

F 10
F 15

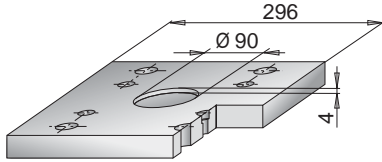
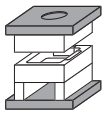

F 10 / 246 296 / S / 1730 2085

27	●	●
36	●	●

F 15 / 246 296 / S / 1730 2085

27	●	●
36	●	●

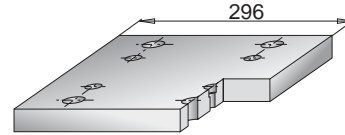

FW 10
FW 15

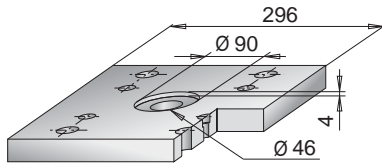
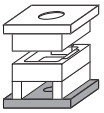

FW 10 / 246 296 / S / 1730 2085

27	●	●
----	---	---

FW 15 / 246 296 / S / 1730 2085

27	●	●
----	---	---

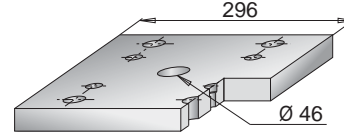

F 20
F 25

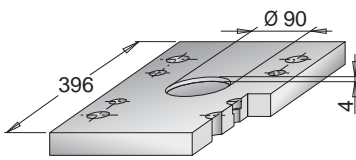
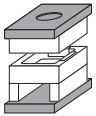

F 20 / 246 296 / S / 1730 2085

27	●	●
36	●	●

F 25 / 246 296 / S / 1730 2085

27	●	●
36	●	●

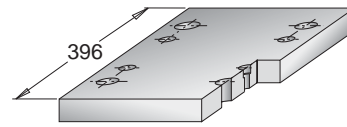

F 40
F 45

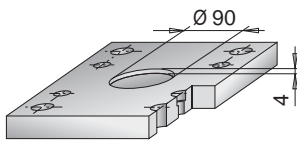
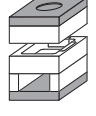

F 40 / 246 296 / S / 1730 2085

22	●	●
27	●	●
36	●	●

F 45 / 246 296 / S / 1730 2085

22	●	●
27	●	●
36	●	●

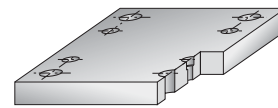

F 60

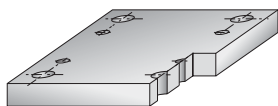
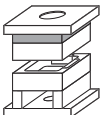

F 60 / 246 296

	S	1730	2085	2312
22	●			
27	●	●	●	●
36	●	●	●	●
46	●	●	●	●
56	●	●	●	●
66	●			

FW 54

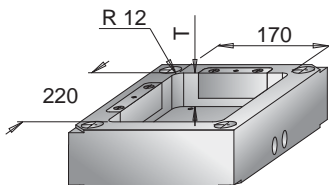
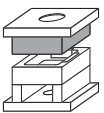

FW 54 / 246 296

E 1200/ 8 x ..
E 2130/ 8 x 2
E 1302/ 5 x 16
E 2670/ 19/..

	S	T	2085	2312
76	40		●	●
86	50		●	●
96	60		●	●



FW 56

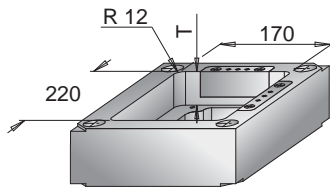
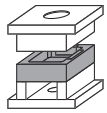

FW 56 / 246 296

E 1200/ 8 x
E 2130/ 8 x 2
E 1302/ 5 x16
E 2670/19/..



/ S / T /	2085	2312
76 40	●	●
86 50	●	●
96 60	●	●

FW 70

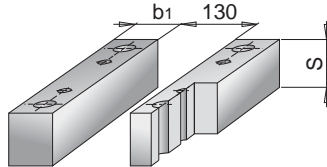
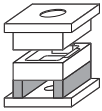

FW 70 / 246 296

T (FW 56)	S
40	56
50	66
60	76

/ b1 / S / 1730	2085
58 56	●
66 66	●
76 76	●

FW 50

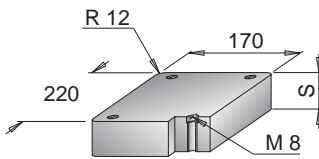

FW 50 / 246 296



/ S /	2311	3.4365
40	●	●
50	●	●
60	●	●

FW 52

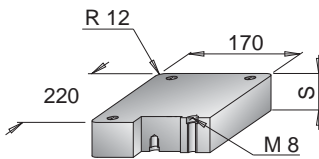

FW 52 / 246 296



/ S /	2311	3.4365
40	●	●
50	●	●
60	●	●

NF 2660

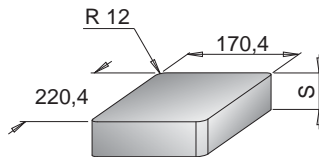

NF 2660 / 170 220



/ S / R /	2083	2311	2343 ^{ESU}	2767
40 12	●	●	●	●
50	●	●	●	●
60	●	●	●	●
70	●	●	●	●

FW 90

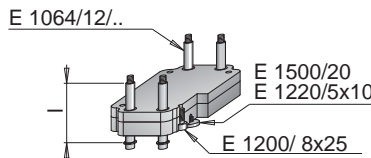
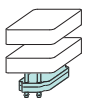

FW 90 / 246 296



/ l / 1730	2085
80	●
90	●
100	●

E 1516

Gewindeeinsatz für Auswerferpaket
Threaded insert for ejector set

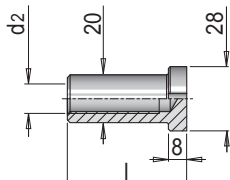

Mat.: 1.7131 ≈ 660 N/mm²

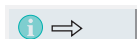

d2	l	Nr. /No.
M12	45	E 1516/12/45
	65	E 1516/12/65

E 1517

Zapfen für Auswerferpaketkupplung
Dowel for ejector set coupling

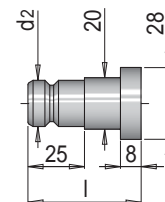

Mat.: 1.2379 ≈ 56 HRC



d2	l	Nr. /No.
18	47	E 1517/18/47

FW 541



**Wechselformplatte düsen-
seitig**

**Change mould fixed half
cavity plate**

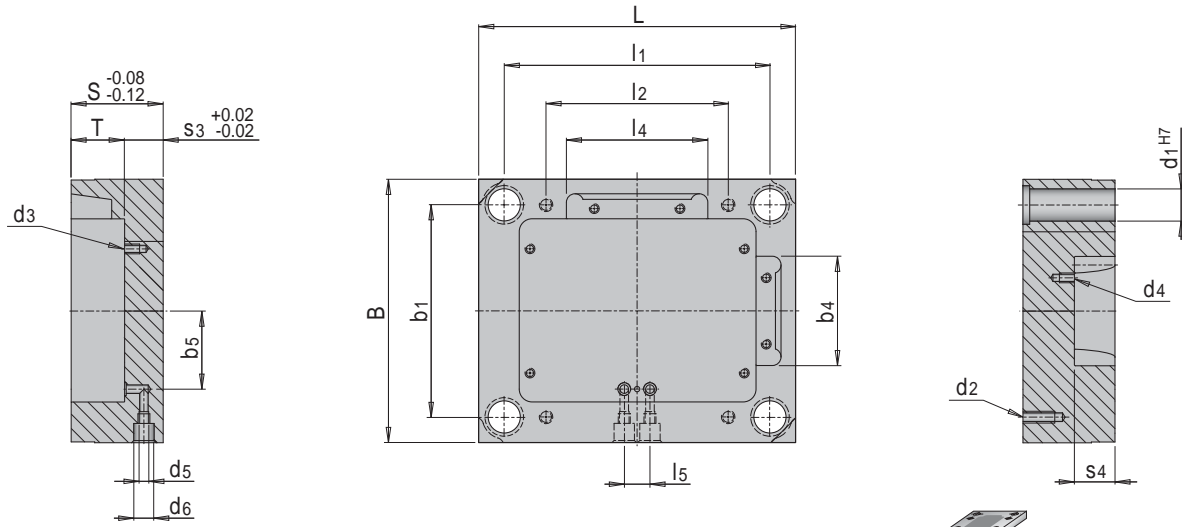

3.2/

F ..



b1	l1	d1	l2	d2	d3	s3	b4	l4	d4	s4	b5	l5	d5	d6	Nr./No.	B	L	S	T	2085	2312		
124	164	20	100	M10	M 6	21	60	84	M 6	19.9	42	24	M10x1	20	FW 541	156	196	46	25	●	●		
						24				23.9										56	32	●	●
						26				29.9										66	40	●	●
156	206	26	136		M 8	24	78	108		23.9	57				FW 541	196	246	56	32	●	●		
						26				29.9										66	40	●	●
										37.9										76	50	●	●
198	248	30	170	M12		36	102	132	M 8	29.9	73				FW 541	246	296	76	40	●	●		
										37.9										86	50	●	●
										44.9										96	60	●	●

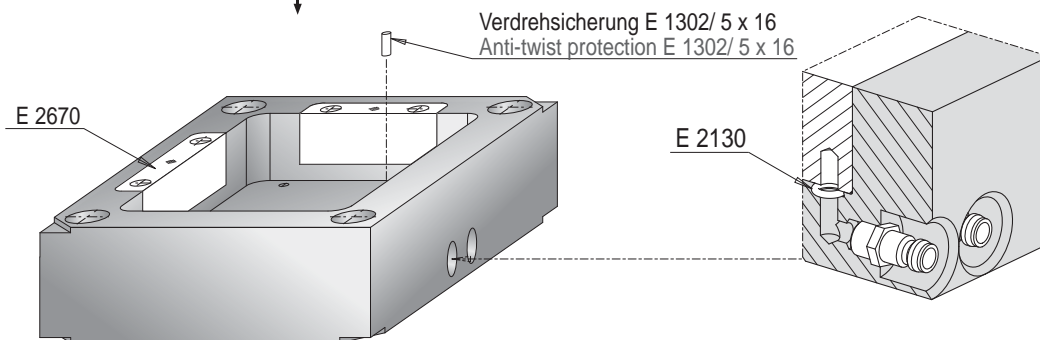
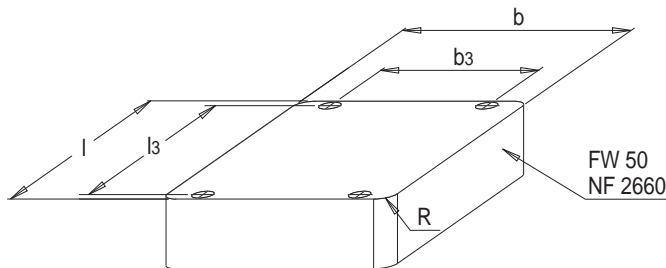

B	L	b	l	R	b3	l3	E 2130
156	196	100	140	10	60	122	E 2130/ 6 x 2
196	246	130	180	12	90	160	E 2130/ 6 x 2
246	296	170	220	12	116	200	E 2130/ 8 x 2

FW 561



Wechselformplatte auswerferseitig

Change mould moving half cavity plate

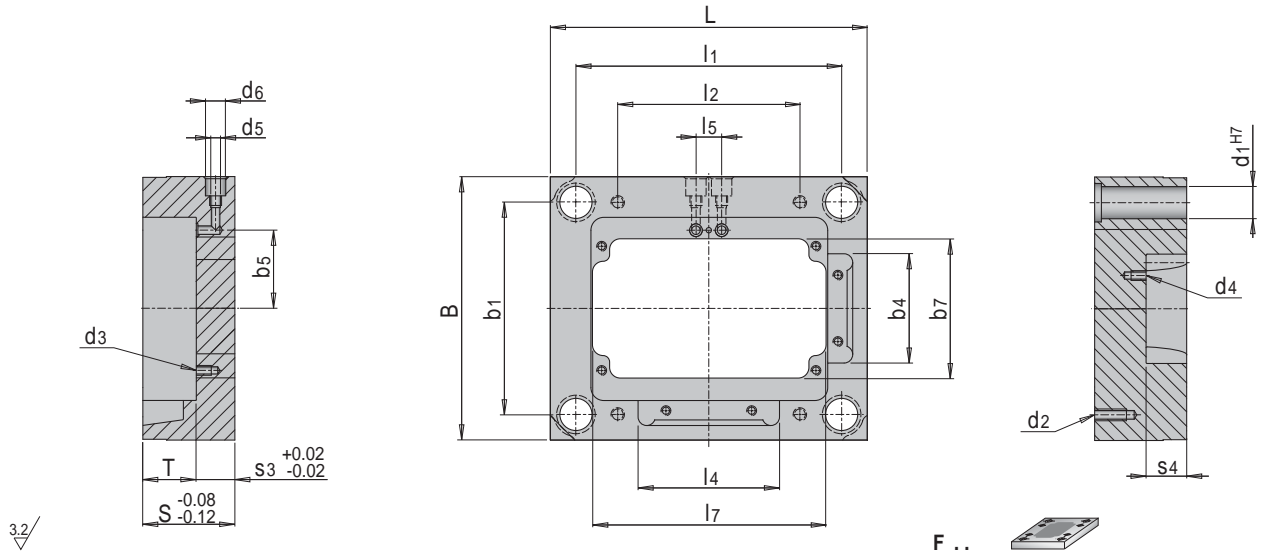

b1	l1	d1	l2	d2	d3	s3	b4	l4	d4	s4	b5	l5	d5	d6	b7	l7	Nr./No.	B	L	S	T	2085	2312
124	164	20	100	M10	M 6	21	60	84	M 6	19.9	42	24	M10x1	20	70	138	FW 561	156	196	46	25	●	●
						24				23.9										56	32	●	●
						26				29.9										66	40	●	●
156	206	26	136		M 8	24	78	108		23.9	57				100	178	FW 561	196	246	56	32	●	●
						26				29.9										66	40	●	●
						36	102	132	M 8	37.9										76	50	●	●
198	248	30	170	M12						29.9	73				130	218	FW 561	246	296	76	40	●	●
										37.9										86	50	●	●
										44.9										96	60	●	●

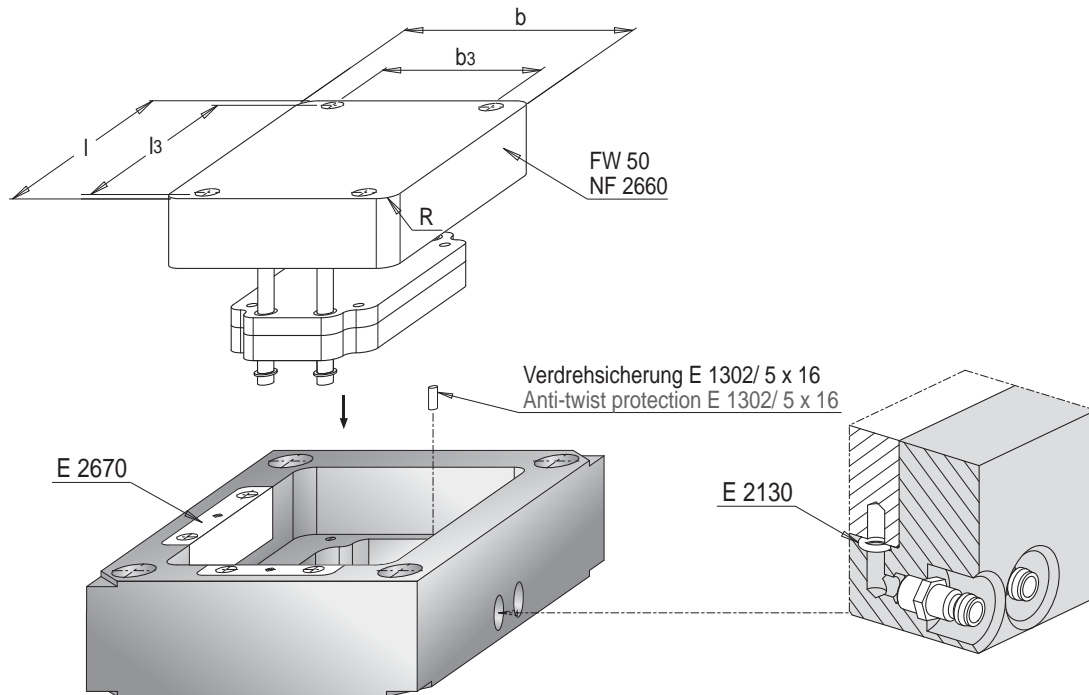

B	L	b	l	R	b3	l3	E 2130
156	196	100	140	10	60	122	E 2130/ 6 x 2
196	246	130	180	12	90	160	E 2130/ 6 x 2
246	296	170	220	12	116	200	E 2130/ 8 x 2

FW 50



Wechseleinsatz, düsen-
seitig

Change insert, fixed half

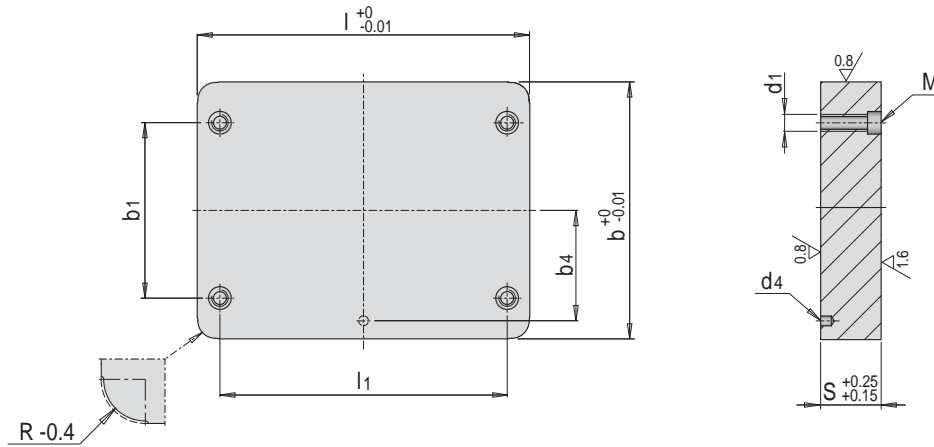

3.2/

F ..

b	l	b1	l1	d1	b4	d4	M	R	Nr./No.	B	L	S	2311	3.4365
100	140	60	122	M 8	42	7.5	M 6	10	FW 50	156	196	25	●	●
130	180	90	160	M10	57		M 8	12	FW 50	196	246	32	●	●
												40	●	●
												50	●	●
170	220	116	200		73				FW 50	246	296	40	●	●
												50	●	●
												60	●	●

Beispiel für Temperierführung

Example for temperature regulating circuits

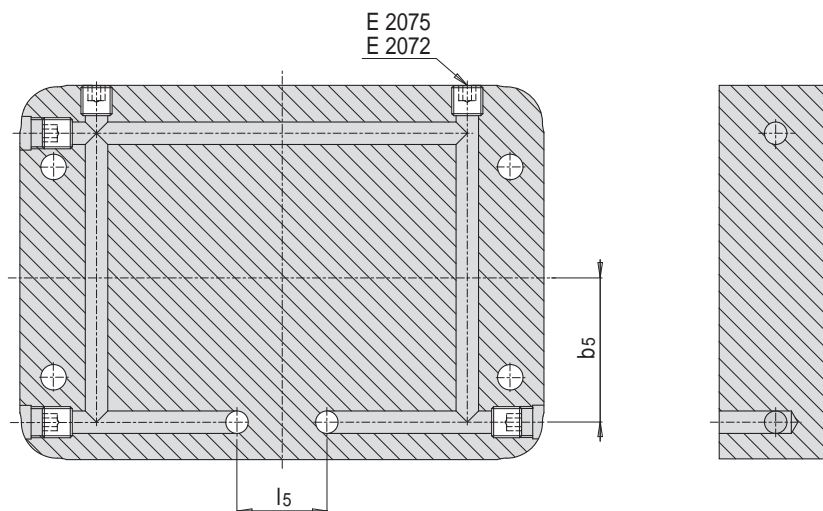

B	L	b5	l5
156	196	42	24
196	246	57	
246	296	73	

FW 52



Wechseleinsatz, auswerferseitig

Change insert, moving half

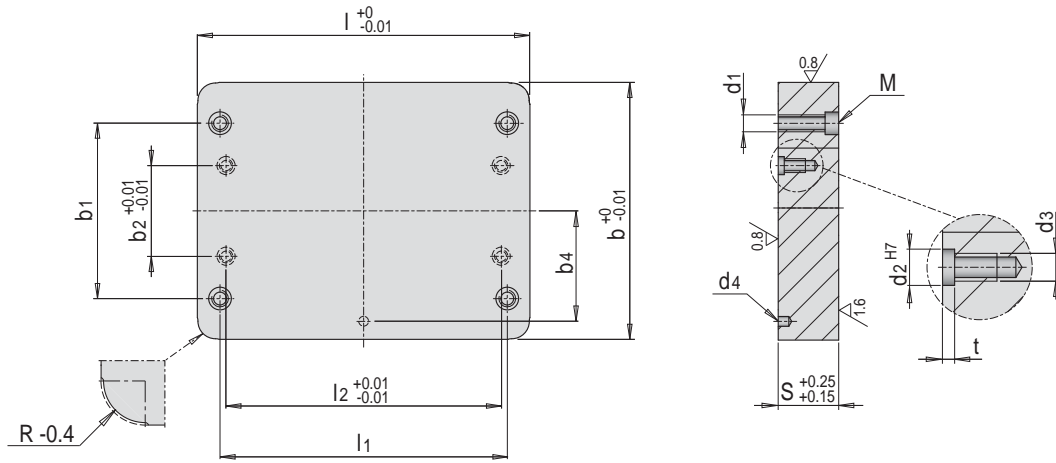

3.2/

F ..



b	l	b1	l1	d1	b2	l2	d2	d3	b4	d4	M	R	t	Nr./No.	/ B L	/ S	/ 2311	3.4365
100	140	60	122	M 8	-	112	10	M 6	42	7.5	M 6	10	4	FW 52	156 196	25	●	●
																32	●	●
									57		M 8	12		FW 52	196 246	40	●	●
																32	●	●
																40	●	●
																50	●	●
					60	192	12	M 8	73					FW 52	246 296	40	●	●
																50	●	●
																60	●	●

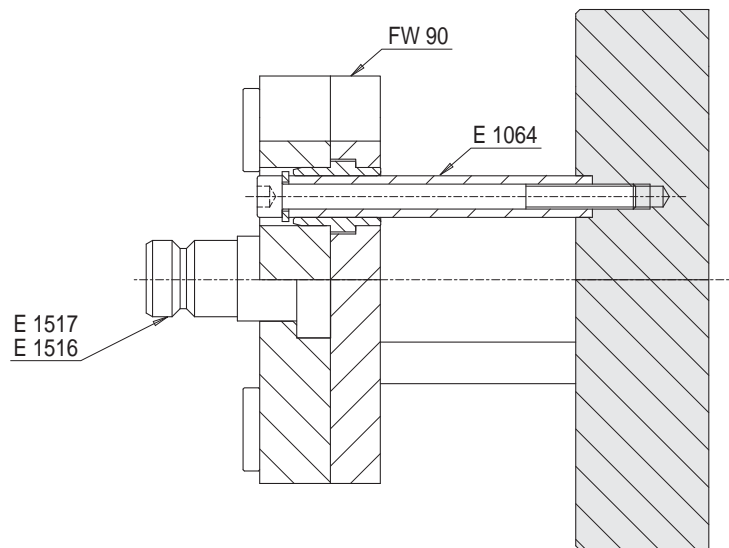

NF 2660



Formeinsatz

Insert

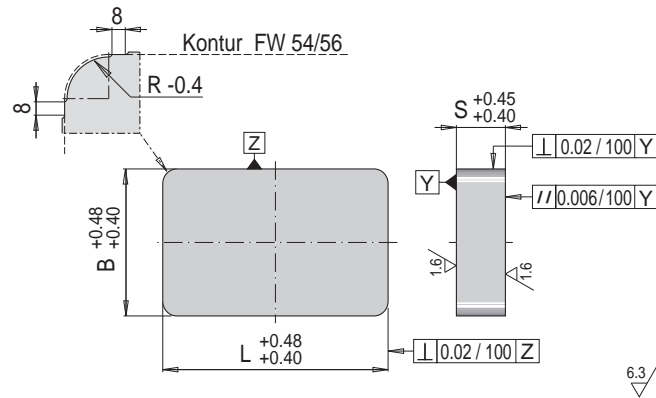

FW 54 / FW 56	Nr./No./	B	L	/	S	/	R	/	2083	2311	2343ESU	2767
156 196	NF 2660 /	100	140	/	25	/	10	/	●	●	●	●
					32				●	●	●	●
					40				●	●	●	●
					50				●	●	●	●
					60				●	●	●	●
					70				●	●	●	●
196 246	NF 2660 /	130	180	/	32	/	12	/	●	●	●	●
					40				●	●	●	●
					50				●	●	●	●
					60				●	●	●	●
246 296	NF 2660 /	170	220	/	40	/	12	/	●	●	●	●
					50				●	●	●	●
					60				●	●	●	●
					70				●	●	●	●

E 2670



Positionierkeil

Positioning wedge

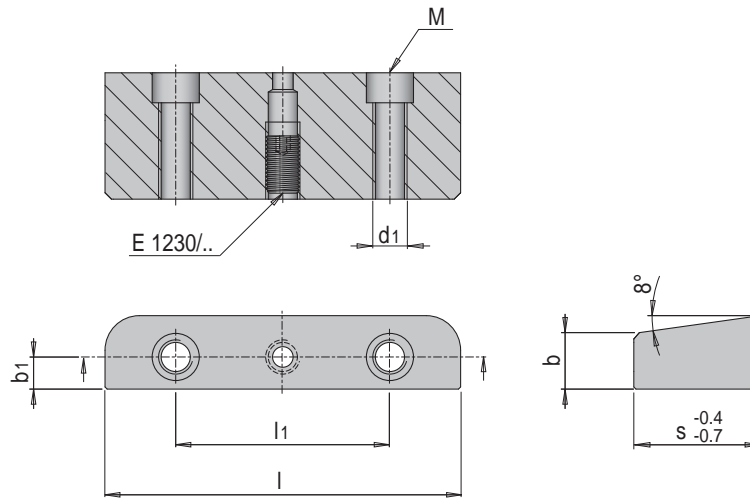

Mat.: 1.2842 ≈ 58 HRC

3.2/

FW 54 / FW 56	b1	l1	d1	E 1230/..	M	b	l	s	Nr./No.
156 196/ 46/25/...	7.5	36	M 8	8 x 10	M 6	13	59	20	E 2670/13/ 59/20
156 196/ 56/32/...				8 x 12				24	E 2670/13/ 59/24
156 196/ 66/40/...				8 x 16				30	E 2670/13/ 59/30
156 196/ 46/25/...	9	50	M 8	8 x 10	M 6	16	83	20	E 2670/13/ 83/20
156 196/ 56/32/...				8 x 12				24	E 2670/13/ 83/24
156 196/ 66/40/...				8 x 16				30	E 2670/13/ 83/30
196 246/ 56/32/...	9	46	M 8	10 x 12	M 6	16	77	24	E 2670/16/ 77/24
196 246/ 66/40/...				10 x 16				30	E 2670/16/ 77/30
196 246/ 76/50/...				10 x 25				38	E 2670/16/ 77/38
196 246/ 56/32/...	10.5	65	M 8	10 x 12	M 8	19	107	24	E 2670/16/107/24
196 246/ 66/40/...				10 x 16				30	E 2670/16/107/30
196 246/ 76/50/...				10 x 25				38	E 2670/16/107/38
246 296/ 76/40/...	10.5	62	M10	10 x 16	M 8	19	101	30	E 2670/19/101/30
246 296/ 86/50/...				10 x 25				38	E 2670/19/101/38
246 296/ 96/60/...				10 x 30				45	E 2670/19/101/45
246 296/ 76/40/...	80	80	M10	10 x 16	M 8	19	131	30	E 2670/19/131/30
246 296/ 86/50/...				10 x 25				38	E 2670/19/131/38
246 296/ 96/60/...				10 x 30				45	E 2670/19/131/45

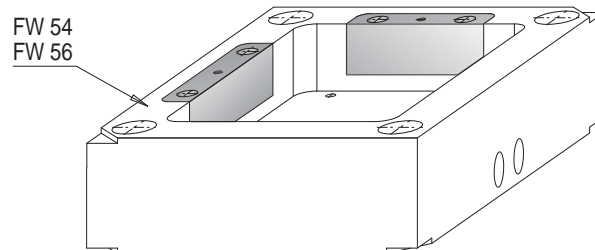

FW 80



Auswerferhalteplatte für Wechselform

Ejector retaining plate for change mould

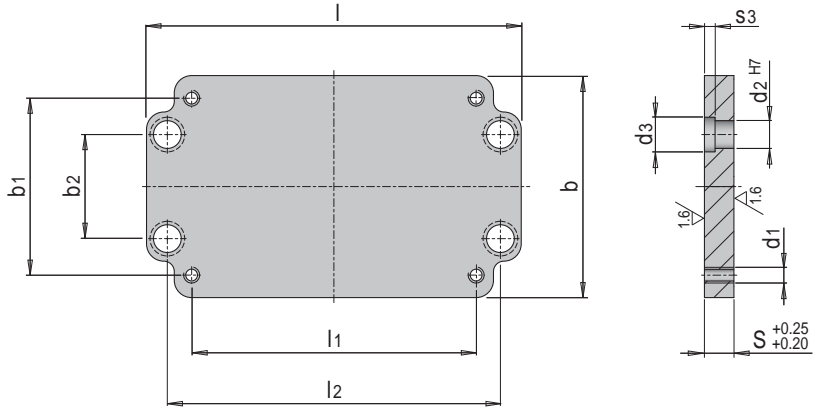

3.2/

F ..

b	l	b1	l1	d1	b2	l2	d2	d3	s3	Nr./No. / B L / S / 1730 2085
68	136	42	84	M8	-	112	14	18	6.1	FW 80 156 196 12 ● ●
98	176	72	124		40	152				FW 80 196 246 12 ● ●
128	216	102	164		60	192	16	20		FW 80 246 296 17 ● ●

FW 85



Auswerfergrundplatte für Wechselform

Ejector base plate for change mould

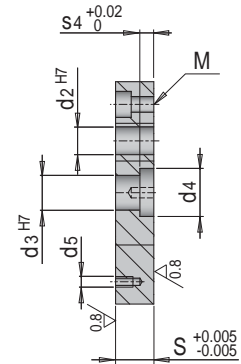
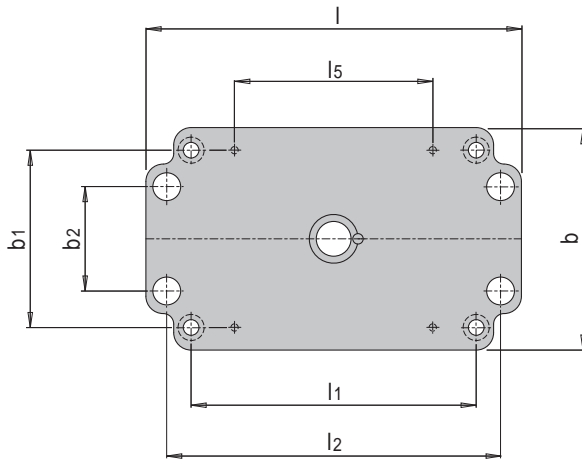

3.2/

F ..



b	l	b1	l1	d2	b2	l2	d3	d4	s4	d5	l5	M	Nr./No.	B	L	S	1730	2085
68	136	42	84	14	-	112	20	28	8	M 5	46	M 8	FW 85	156	196	17	●	●
98	176	72	124		40	152					74		FW 85	196	246	17	●	●
128	216	102	164	16	60	192					114		FW 85	246	296	22	●	●

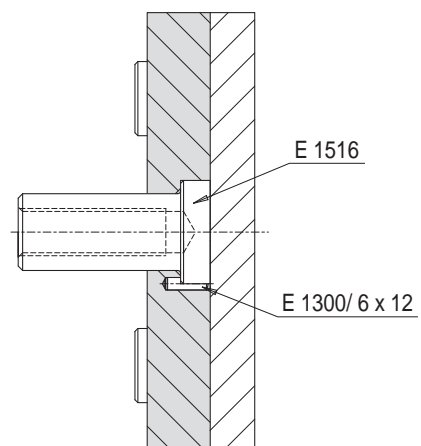
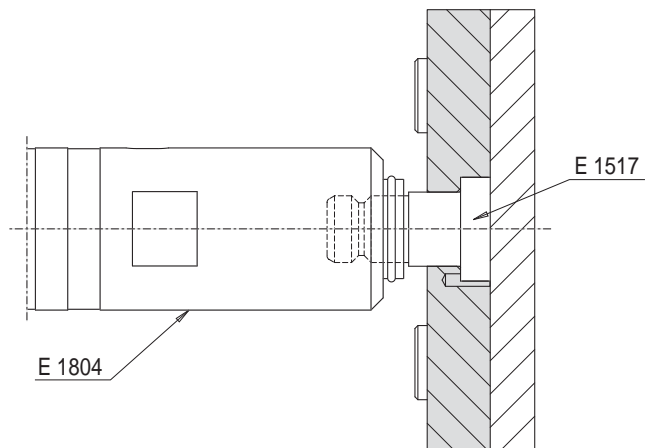

E 1064



Führungseinheit für Auswerferpaket

Guiding unit for ejector set

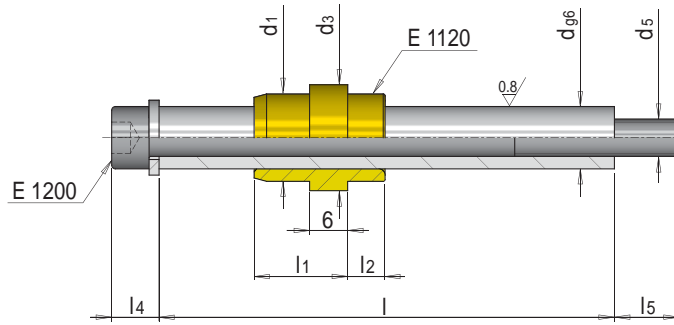

Mat.: St / 2.0598

l ₁	d ₁	l ₂	d ₃	l ₄	l ₅	d ₅	d	l	Nr. /No.
12	14	9	17	7.6	8.4	M 6	10	60	E 1064/10/ 60
					10.4			73	E 1064/10/ 73
					8.4			85	E 1064/10/ 85
17	16		19	9.6	13.4	M 8	12	95	E 1064/10/ 95
								80	E 1064/12/ 80
								90	E 1064/12/ 90
								100	E 1064/12/100

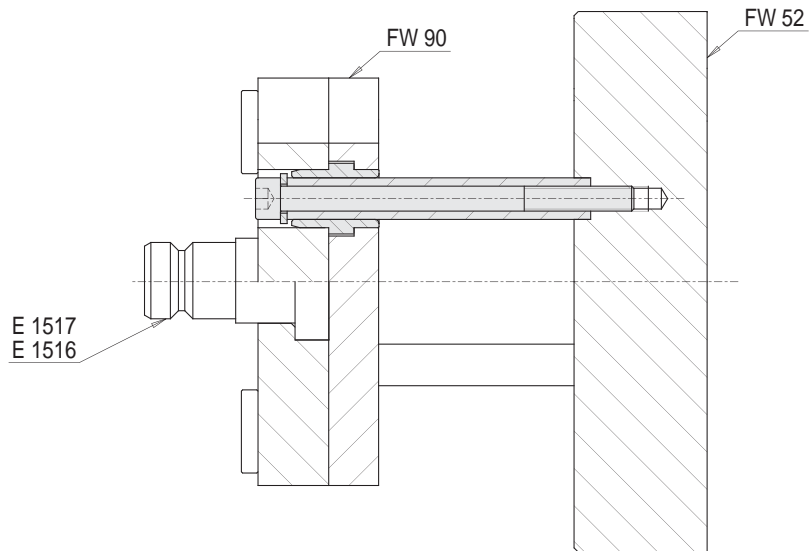

E 1516



Gewindeinsatz für Auswerferpaket

Threaded insert for ejector set

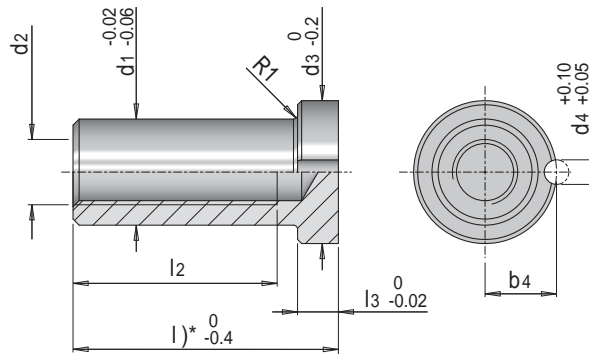

Mat.: 1.7131 $\approx 660 \text{ N/mm}^2$

d4	l3	b4	d1	d3	l2	d2	l	Nr./No.
6	8	14	20	28	30	M12	45	E 1516/12 / 45
					35		65	E 1516/12 / 65
		17.5	26	35	50	M16	65	E 1516/16 / 65
							100	E 1516/16 /100
		17.5	26	35	50	M16x1.5	65	E 1516/16x1.5/ 65
							100	E 1516/16x1.5/100
		20	30	40	45	M20	65	E 1516/20 / 65
					50		100	E 1516/20 /100
		20	30	40	45	M22x1.5	65	E 1516/22x1.5/ 65
					50		100	E 1516/22x1.5/100
		23	36	46	45	M24x1.5	65	E 1516/24x1.5/ 65
					50		100	E 1516/24x1.5/100

l)* Bei Bedarf ablängen
Cut to length if necessary

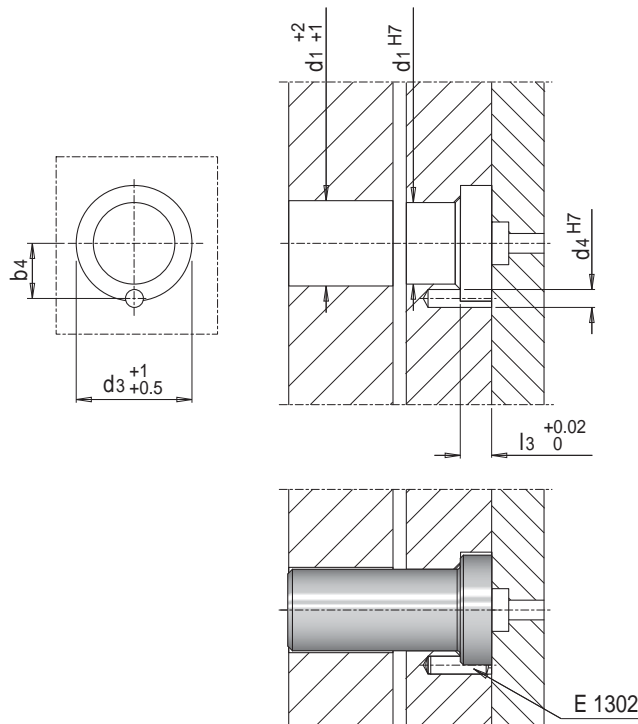

E 1517



Zapfen für
Auswerferpaketkupplung

Dowel for ejector set
coupling

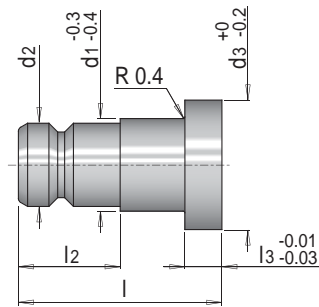

Mat.: 1.2379 \approx 56 HRC

d1	l2	l3	d3	d2	l	Nr./No.
20	25	8	28	18	47	E 1517/18/47

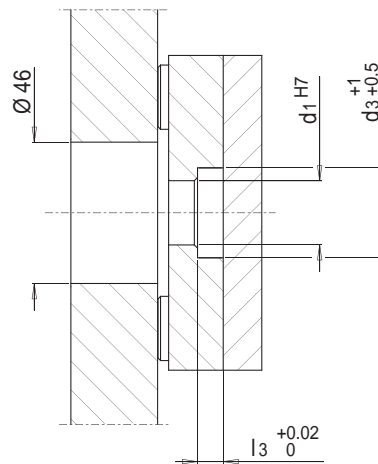
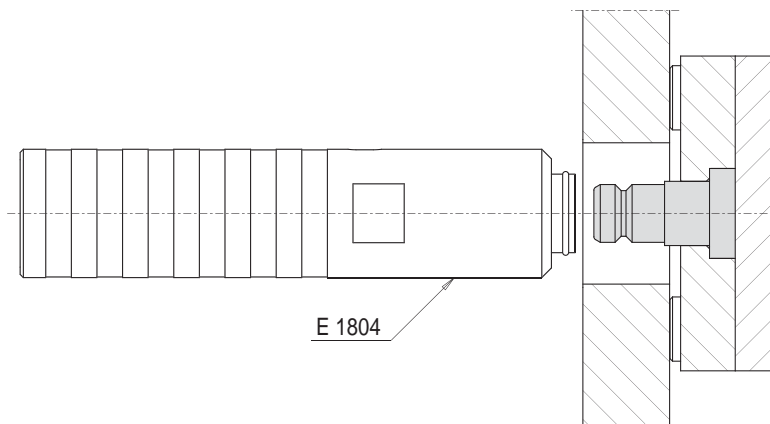

E 1518



Zapfen für
Auswerferpaketkupplung
mit Gewinde

Dowel for ejector set
coupling, threaded

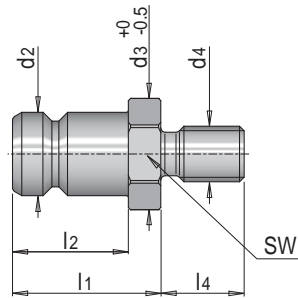

Mat.: 1.2379 ≈ 56 HRC

SW	l ₂	d ₃	l ₄	d ₂	l ₁	d ₄	Nr./No.
22	25	25	16	18	32	M12	E 1518/18/ 32/ 12
24		27	21			M16	E 1518/18/ 32/ 16

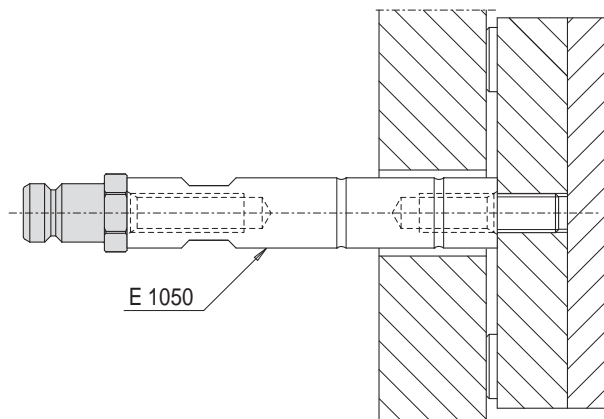
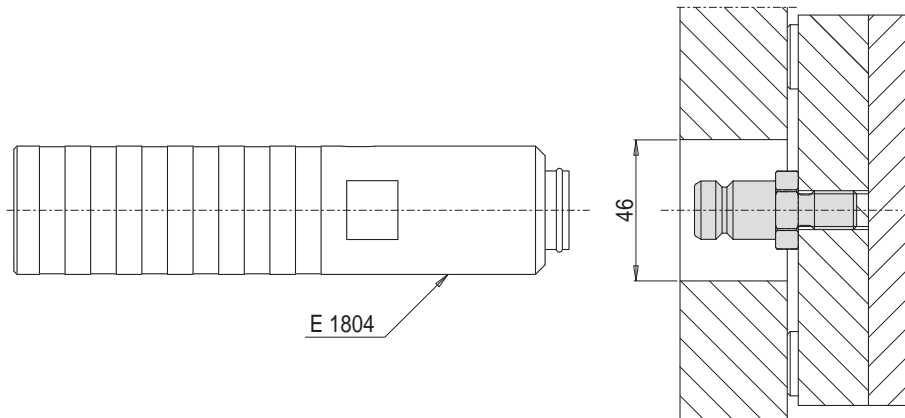

E 1804



Auswerferpaketkupplung

Ejector set coupling

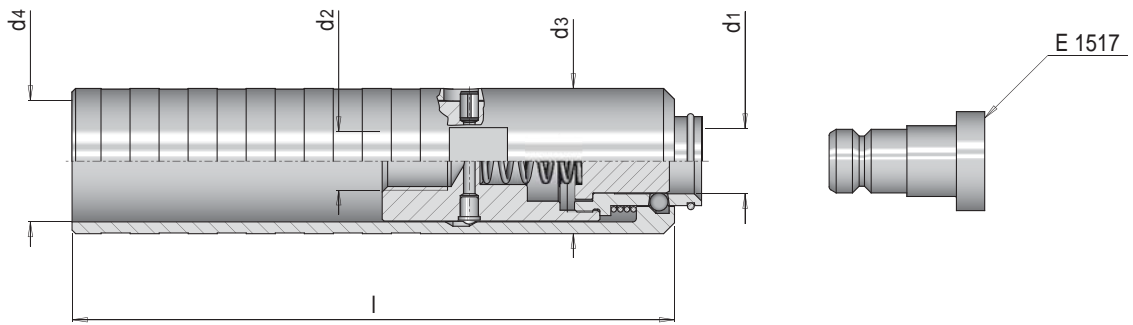

l_1	d_3	d_4	d_1	d_2	l	Nr. /No.
117	40	34	18	M12	166	E 1804/18/12/166
				M16		E 1804/18/16/166

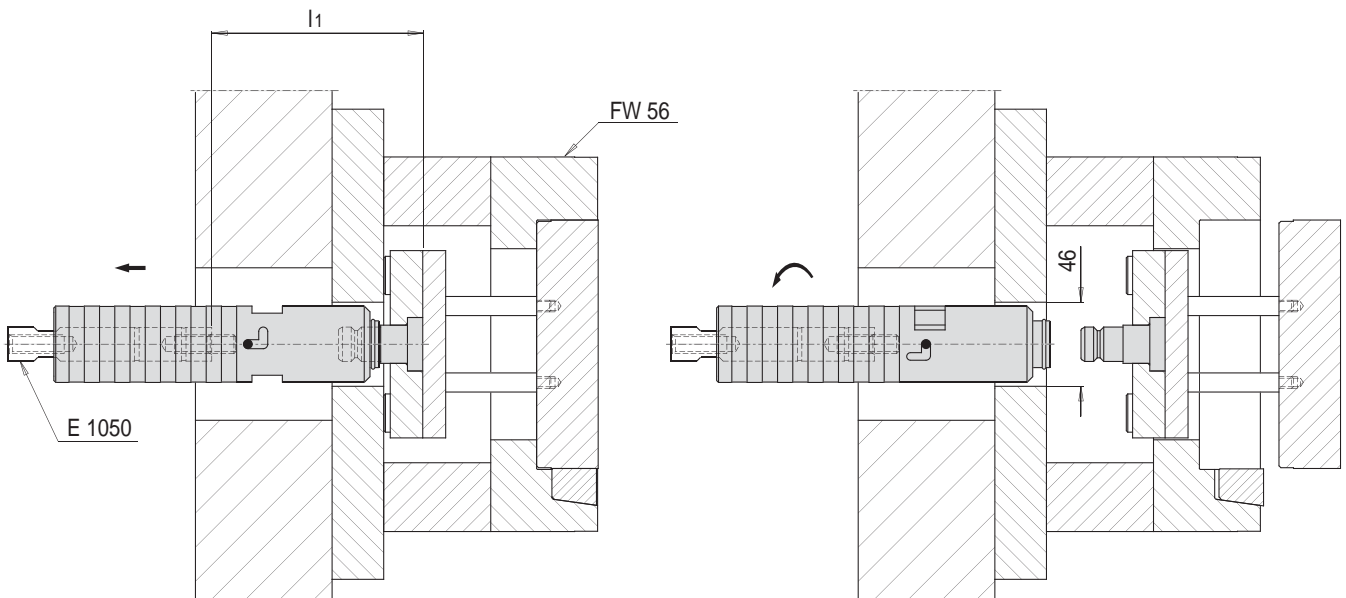

Präzision und Maßhaltigkeit durch strengste Qualitätsrichtlinien

meusburger.com



Precision and accurate dimensions through very strict quality guidelines

© 2011/Meusburger Georg GmbH & Co KG. Alle Rechte vorbehalten. Kein Teil dieser Unterlagen darf ohne ausdrückliche schriftliche Erlaubnis der Meusburger Georg GmbH & Co KG für irgendwelche Zwecke vervielfältigt oder übertragen werden. Druckfehler und Irrtümer sowie technische Änderungen vorbehalten.



meusburger[®].com

Meusburger Georg GmbH & Co KG | Formaufbauten | Kesselstr. 42 | A-6960 Wolfurt
T 00 43 (0) 55 74 / 67 06-0 | F -11 | sales@meusburger.com | www.meusburger.com